

# SERIES 433 Triple Set <sup>®</sup>

## Installation Instructions



May 14, 2024

WHERE WINDOWS ARE JUST THE BEGINNING<sup>®</sup>



# TABLE OF CONTENTS

<u>SECTION</u>	<u>PAGE</u>
I. General Notes.....	3
II. Parts Identification Charts.....	4
III. Fabrication	
A. Drilling Template (Offset Screw Spline Verticals).....	12
B. Drilling Template (Offset Shear Block Verticals).....	15
C. Drilling Template (Center-Set Screw Spline Verticals).....	18
D. Drilling Template (Center-Set Shear Block Verticals).....	20
E. Drilling Template (Offset @ 90° Corner Horiz/Head /Sill).....	23
F. Drilling Template (Offset & Center-Set Shear Blocks @ Sills).....	25
G. Drilling Template (Offset & Center-Set Shear Blocks @ Horiz).....	27
H. Drilling Template (Offset Glazed Head & Sill Through).....	29
IV. Unit Assembly	
A. Screw Spline (Offset and Center-Set).....	32
B. Shear Block (Offset and Center-Set).....	40
C. Head and Sill Through (Offset).....	43
D. Screw Spline 90° Corner (Offset).....	44
E. Rolled Arch Top & Sloped Top (Center-Set).....	45
F. Adjustable Height Side Lite (Offset).....	46
V. Door Frame Installation.....	49
VI. Subsill Fabrication and Installation.....	51
VII. Corners.....	59
VIII. Installation.....	62
IX. Glazing.....	73
X. Door Stop Installation.....	90

Note: Please reference EFCO's "Understanding Condensation" brochure which can be obtained through your EFCO representative.

Condensation will form on any surface when unfavorable conditions (interior temperature and relative humidity and exterior temperature) are present. When the formation of excessive condensation is a concern, it is highly recommended that a design professional is utilized to perform an analysis of the shop drawings to recommend the best possible installation methods. Please contact your EFCO representative for information on EFCO's Thermal Analysis Services.

Many current installation practices lead to an increase in the possibility of the formation of condensation. Though not all inclusive, the list of examples below illustrates conditions under which condensation is likely to occur:

1. Bridging system thermal break with non-thermally broken metal flashing or lintels that are exposed to the exterior
2. System exposure to cold air cavities
3. Interior relative humidity levels not maintained at recommended levels, see EFCO's "Understanding Condensation" brochure
4. Inadequate separation between system and surrounding condition at perimeter
5. Product combinations during the shop drawing stage that result in bridging thermal breaks of one or all products involved

### SECTION I: General Notes

The "433 TRIPLE SET" is a framing system that has many advantages over other framing systems. It can be used as a single-span storefront window wall, a punched opening system, or as a ribbon window system. The main advantage is the ability to set the glass plane in three different positions within the same elevation.

The 433 Triple Set system contains primarily stock length systems with in-the-field fabrication. Entrance doors are also a designed part of these systems, utilizing frames that can accommodate many types of doors and hardware combinations.

1. Check the shop drawings, installation instructions, and glazing instructions to become thoroughly familiar with the project. The shop drawings take precedence and include specific details for the project. The installation instructions are of a general nature and cover the most common conditions encountered.
2. Check all materials on arrival and be sure you have everything required to begin installation. See Section II "PARTS IDENTIFICATION" for parts cross-reference.
3. All work should start from benchmarks and/or column centerlines as established by the architectural drawings and the general contractor. Installers should check building construction for compliance with architectural documents to ensure the proper window system foundation is available before installation.
4. Throughout these instructions the term "SEALANT" will appear. For the purposes of these instructions, sealant is to be defined as the following:

SEALANT – A weather resistant, gunnable liquid filler which when cured provides a resilient, flexible (+ 50% movement capability) air and water seal between similar and dissimilar materials.

All sealants must meet ASTM C 920, CLASS 50.

When required Butyl sealant – A non-skinning, non-hardening material (NAAMM Reference Standard 5C-1)

NOTE: All sealant must be compatible with all surfaces where adhesion is required, including other sealant surfaces. All frame surfaces should be clean and dry. All perimeter substrate shall be cleaned and properly treated to receive sealant.

5. All materials are to be installed plumb, level, and true.
6. Protect materials after erection. Cement, plaster, alkaline solutions, and acid based materials can be harmful to the finish. Clean exposed finished surfaces with a mild detergent and water. No abrasive cleaning agent should be used.

# SECTION II: Parts Identification Chart

## Vertical Parts:

Drawings on this page are not to scale.

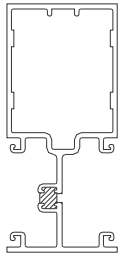

**8349**  
Offset Glazed Vertical  
-Shear Block Only-

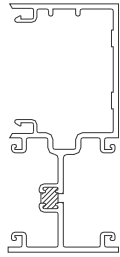

**8353**  
Offset Glazed Vertical  
Use w/8352



**8352**  
Offset Glazed Vertical  
Filler  
Use w/8353

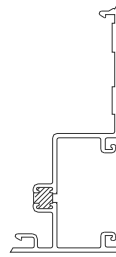

**8354**  
Inside/Outside Offset  
Vertical Half  
Mates w/Itself

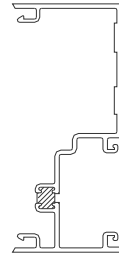

**8355**  
Offset to Center-Set  
Deep Vertical Half  
Use w/8358

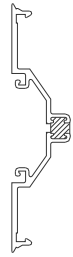

**8358**  
Center-Set to Offset  
Shallow Vertical Half  
Use w/8355

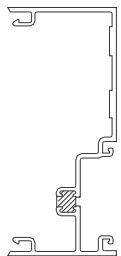

**8356**  
Offset to Center-Set  
Shallow Vertical Half  
Use w/8359

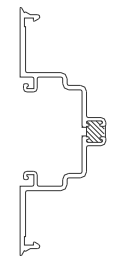

**8359**  
Center-Set to Offset  
Deep Vertical Half  
Use w/8356

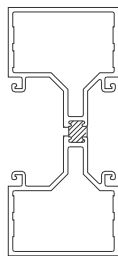

**8357**  
Center-Set Glazed  
Vertical  
-Shear Block Only-



**8360**  
Center-Set to Center-Set  
Shallow Vertical Half  
Use w/8361

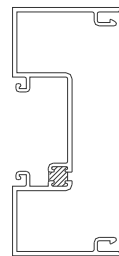

**8361**  
Center-Set to Center-Set  
Deep Vertical Half  
Use w/8360

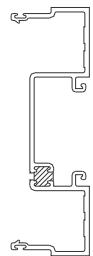

**8397**  
Offset Glaze Male  
Expansion Mullion Half  
Use w/8396

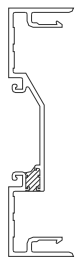

**8396**  
Center Glaze Female  
Expansion Mullion Half  
Use w/8397



**8394**  
Offset Glaze Female  
Expansion Mullion Half  
Use w/8395

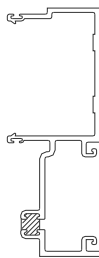

**8395**  
Offset Glaze Male  
Expansion Mullion Half  
Use w/8394

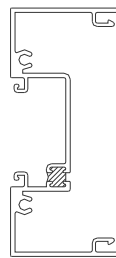

**4470**  
Center Glaze Open Back  
Sill/Vertical



**4383**  
Screw Spine Sidelite  
Door Jamb Deep Pocket  
Filler Use w/4371 & 4372

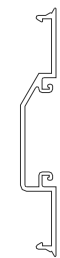

**4393**  
Vertical Mullion Half  
Shallow Pocket Non-  
Thermal

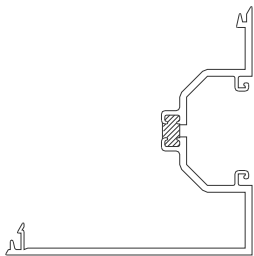

**4356**  
4 1/2" Vertical  
Mullion Half

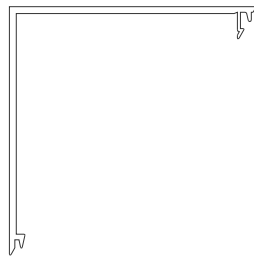

**4357**  
4 1/2" Vertical Corner

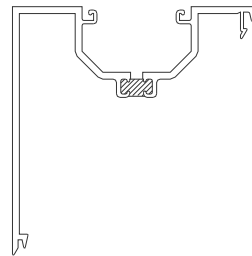

**4358**  
4 1/2" Single Pocket  
Vertical Corner

## **SECTION II: Parts Identification Chart**

### **Vertical Parts cont.:**

Drawings on this page are not to scale.

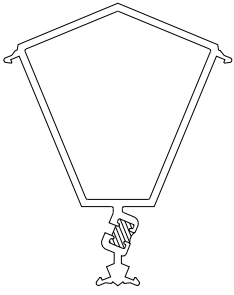

**8380**

135° Corner Mullion  
Use w/8355, 8356 & 8361

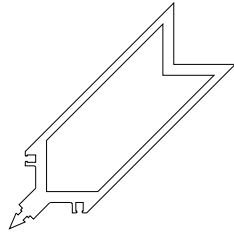

**8475**

90° Structural Glaze Corner  
Mullion

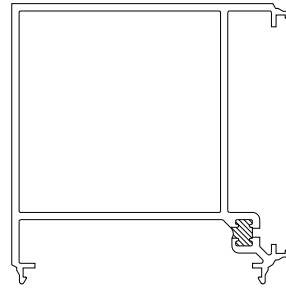

**8381**

90° Corner Mullion  
Use with  
8355, 8356 & 8361

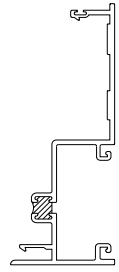

**4380**

Out side to Inside Set  
Expansion Mullion  
Mates with Itself

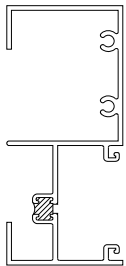

**8439**

Structural Glaze  
Jamb w/Head & Sill  
through

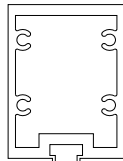

**8389**

Structural Glaze  
Mullion

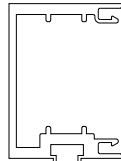

**8387**

Screw Spline  
Structural Glaze Mullion  
Use w/8388



**8388**

Screw Spline Structural  
Glaze Mullion Filler  
Use w/8387

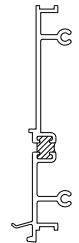

**16E1**

Adjustable Sidelite  
Vertical



**9838**

Adjustable Sidelite  
Dead Load Support Tube

# SECTION II: Parts Identification Chart

## Horizontal Parts:

Drawings on this page are not to scale.

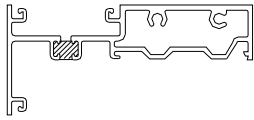

**8363**  
Offset Intermediate  
Horizontal/Head  
Use w/8365

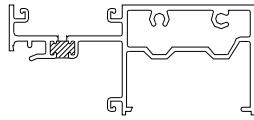

**8366**  
Offset Outside Set/ Outside  
Glazed, Inside Set/Inside Glazed  
Horizontal/Head  
Use w/8364 & 8367

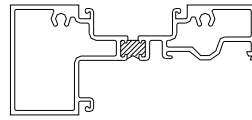

**8372**  
Center-Set Horizontal  
Use w/8368

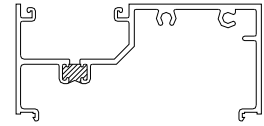

**8362**  
Offset Sill  
Used @ 2S44 Subsill

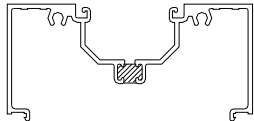

**8375**  
Center-Set Sill  
Used @ 2S44 Subsill

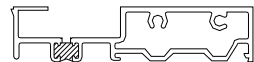

**8393**  
Structural Glaze Head  
Use w/8365 & 8382

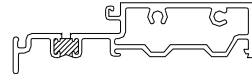

**8385**  
Structural Glaze Horizontal  
Use w/8365 & 8386

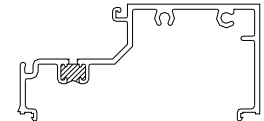

**8384**  
Structural Glaze Sill  
Use w/8382

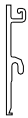

**8382**  
Head & Sill Face Cover  
Use w/8384 & 8393



**8386**  
Horizontal Face Cover  
Use w/8385



**8367**  
Horizontal Face Snap  
Use w/8366



**8364**  
Offset Horizontal Filler  
Use w/8366



**8365**  
Offset Glazing Bead  
Use w/8363, 8385 & 8393



**8368**  
Center-Set Glazing Bead  
Use w/8372



**E178**  
Frame Receptor Closer  
Use w/1510



**1510**  
Frame Receptor  
Use w/E178

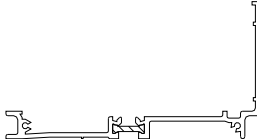

**2S44**  
High Performance Subsill  
Use w/8362 & 8375 Sills



**4471**  
Fill & Debridged Subsill

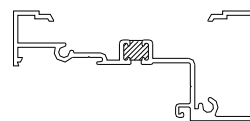

**4369**  
Center-Set Open Back Head



**8746**  
Perimeter Adaptor

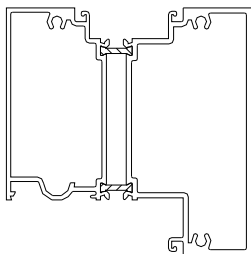

**3G45**  
4 1/2" Horizontal for Center-  
Set Outside Glazed

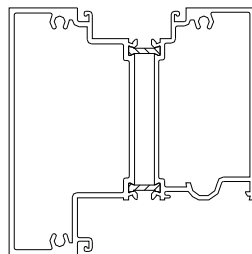

**3G46**  
4 1/2" Horizontal for Center-  
Set Inside Glazed

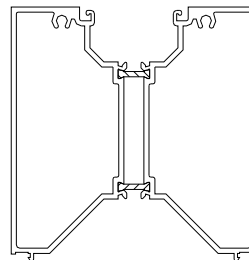

**3G48**  
4 1/2" Sill for Center-Set  
Glazing

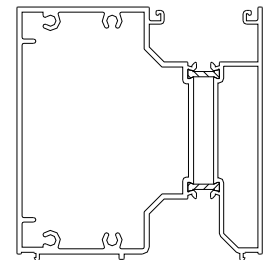

**4G33**  
4 1/2" Inside Set  
Fixed Stop

# SECTION II: Parts Identification Chart

## Horizontal Parts:

Drawings on this page are not to scale.



**16B9**  
4 1/2" Offset Head & Sill  
Face Cover  
Use w/4G31

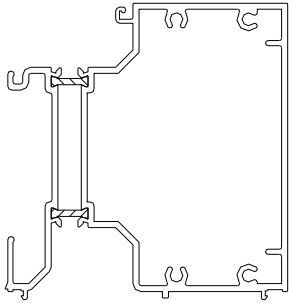

**4G31**  
4 1/2" Outside Set Sill  
Use w/16B9



**16B3**  
4 1/2" Offset Intermediate  
Horizontal Face Cover  
Use w/4G30

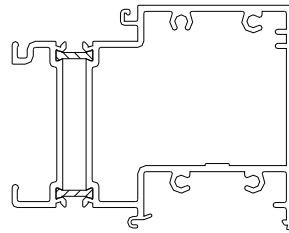

**4G30**  
4 1/2" Outside Set  
Intermediate Horizontal  
Use w/16B3

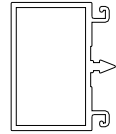

**16C7**  
2-Part Mullion Half

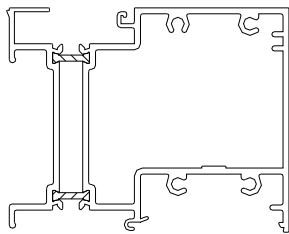

**4G29**  
4 1/2" Offset  
Glazed Head

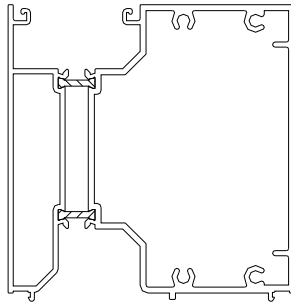

**4G32**  
4 1/2" Outside Set Sill  
Fixed Stop

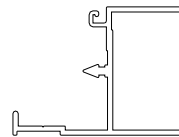

**16C8**  
2-Part Perimeter  
Interior Half

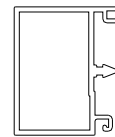

**16C9**  
2-Part Perimeter  
Exterior Half



**3S67**  
Adjustable Sidelite Sill

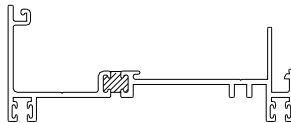

**16D9**  
Adjustable Sidelite  
Horizontal

# SECTION II: Parts Identification Chart

Drawings on this page are not to scale.

## Door Frame Parts:

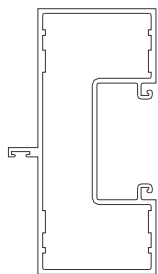

**9209**

Single Acting Door Jamb

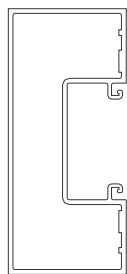

**9208**

Double Acting Door Jamb

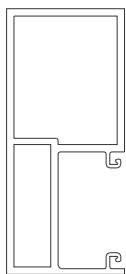

**8374**

Door Jamb for Offset Glazing  
Use 9154/9155 Door Stops  
Use 8377/8378 Transom Stops

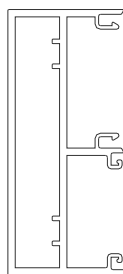

**4374**

Offset Glazed Door Jamb for Screw Spline Sidelites

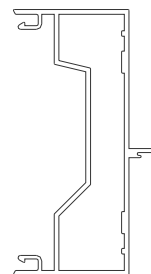

**4371**

Standard Door Jamb for Screw Spline Sidelites

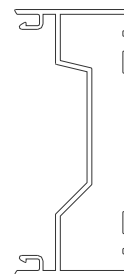

**4372**

Center Pivot Door Jamb for Screw Spline Sidelites

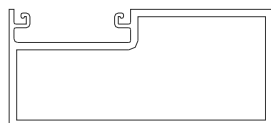

**8373**

Door Header @ Surface Closure  
Use 4437/9155 Door Stop

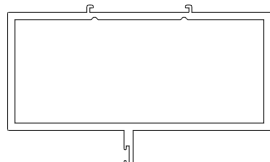

**9234**

Single Acting Door Header  
Use 9123 for 1" Glass

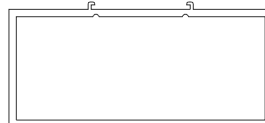

**9227**

Dual Acting Door Header  
Use 4437/9155 Door Stop



**2556**

2 X 4 1/2 X 1/8" Wall Tube  
Use 8377 & 8378 for Offset Glazing @ C.O.C.  
Use 4437/9155 Door Stop



**8377**

Applied Transom Glazing Stop  
Use w/8378



**8378**

Transom Glass Stop  
Use w/8377



**9123**

Transom Glazing Bead  
Use w/9227 & 9234



**9154**

Applied Jamb Door Stop  
Use w/9155 Cover



**4437**

Applied Head Door Stop  
Use w/9155 Cover



**9155**

Door Stop Cover  
Use w/9154 & 4437 Stops



**9257**

Snap-In Door Stop  
Use w/ 8357



**4376**

Snap-In Transom Glass Adapter  
Use w/9208 & 9209

## Fasteners:



**STV2**

#14-10 X 1/2  
HW-SMS 18-8 AB



**STC8**

#12-140 X 1 1/4  
PH-SMS 18-8 TYPE 25  
Assembly Screw



**STD1**

#12-24 X 1/2  
TH-SMS 18-8  
TYPE 23



**STB9**

#12-11 X 1/2  
RH-SMS 18-8 A



**STD8(Cl)/S117(Brz)**

#10-12 X 3/4  
FH-SMS 18-8 AB



**STB5**

#12-11 X 1 5/8  
PH-SMS 18-8 A



**STT6**

#8-18 X 9/16  
PH-SMS 18-8 TEK  
Door Stop/Transom Stop  
Fastener



**SPZ1**

#8-18 X 3/4  
PH-SMS 18-8 AB  
Adjustable Sidelite  
Assembly Fastener

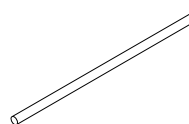

**FW95**

3" Rod for Horizontal  
Dead Load Support  
at Intermediate Vert.

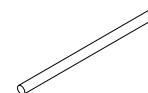

**FW96**

2" Rod for Horizontal  
Dead Load Support  
at Perimeter Vert.



# SECTION II: Parts Identification Chart

## Shear Blocks:

Drawings on this page are not to scale.

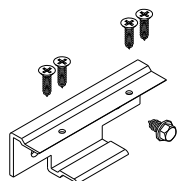

**K918**

LH or RH C.O.C. Header Shear Block Pkg. for Pivots, Butts or Cont. Hinge  
Use w/ 9227, 9234 or 2556

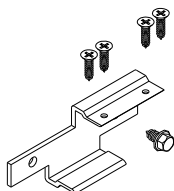

**K919**

RH STD Door Header Shear Block Pkg. for Pivots, Butts or Cont. Hinge  
Use w/8373

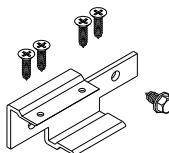

**K923**

LH STD Door Header Shear Block Pkg. for Pivots, Butts or Cont. Hinge  
Use w/8373

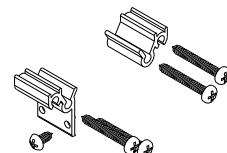

**K924**

Shear Block Pkg. for Center-Set Horizontal/Head  
Use w/8372

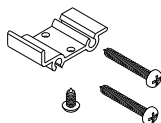

**K925**

Shear Block Pkg. for Offset Horizontal/Head  
Use w/8363,8366,8385 or 8393

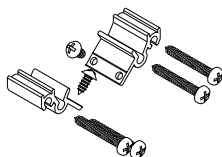

**K926**

Shear Block Pkg. for Center-Set Sill  
Use w/8375

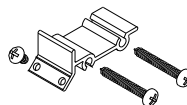

**K927**

Shear Block Pkg. For Offset Sill  
Use w/8362 & 8384  
Use (2) w/4G31, 4G32 & 4G33

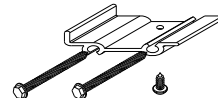

**KN52**

Shear Block Pkg. for 90° Structural Glaze Corner @ Head/ Horizontal  
Use w/8475

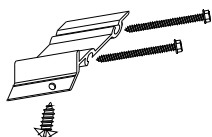

**KN53**

Shear Block Pkg. for 90° Structural Glaze Corner @ Sill  
Use w/8475

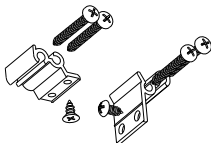

**KN67**

Shear Block Pkg. for Center Set Head  
Use w/4369

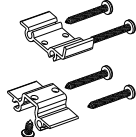

**KN91**

Shear Block Pkg. for 4 1/2" Horizontal/Head  
Use w/4G30 & 4G29

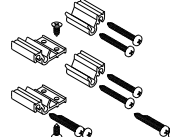

**KN69**

Shear Block Pkg. for 4 1/2" Center-Set Horizontal/Head  
Use w/3G45

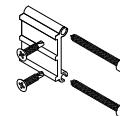

**KN92**

Shear Block Pkg. for 2-Piece Rolld Horizontal

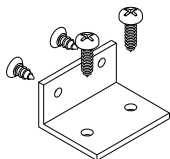

**KN73**

Shear Block Pkg. for Offset Vertical to Horizontal thru Attachment

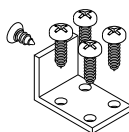

**KN74**

Shear Block Pkg. for Center Set Vertical to Horizontal thru Attachment

## Setting Blocks:

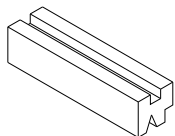

**HN64**

Setting Block @ Adjustable Sidelite Horizontal (16D9)

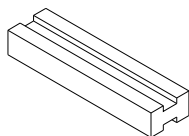

**HN38**

Setting Block @ Applied Transom Glass Stops 8377 & 8378

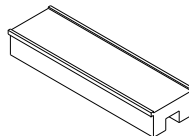

**HN32**

Setting Block @ Sill (or Applied Transom Glass Stops 9123)

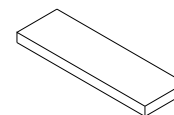

**HN92**

Setting Block @ Horizontals (including 8373 Door Header)

# SECTION II: Parts Identification Chart

Drawings on this page are not to scale.

## Glazing Gaskets:



**W199**

Standard Glazing Gasket  
1" Infill @ 1" Pocket



**W166**

Glazing Gasket for  
Oversized Glass 1 1/16"  
Infill @ 1" Pocket



**W165**

Glazing Gasket for  
Undersized Glass 3/4" Infill  
@ 1" Pocket

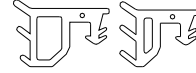

**W165/W199**

Glazing Gasket for Undersized  
Glass .906"- .922" Infill @ 1"  
Pocket-Use W165 Exterior  
and W199 Interior



**WM80**

Tape for  
SSG Mullions



**W115**

Glazing Gasket for 2-  
Piece Rolled Framing  
@ 1" Pocket



**WM10**

Tape for 90° . . . .  
SSG Mullion



**W161**

Adjustable Sidelite  
Gasket at Sill

## W



**WA04**

Standard Weather Seal  
@ Subframes 1510 & E178



**W138**

Standard Weather Seal  
@ Door Stops



**W104**

Standard Weather Seal  
@ Expansion Mullion and  
Adjustable Sidelite

## Drill Jigs:

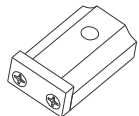

**DJ12**

Offset Glazing Head &  
Horizontal Drill Fixture

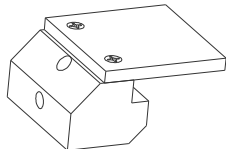

**DJ13**

Offset & Center-Set  
Sill Drill Fixture

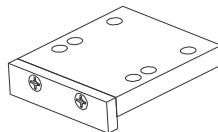

**DJ14**

Shear Block Drill Fixture for  
Vertical Fabrication

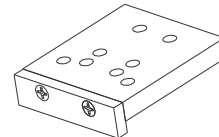

**DJ15**

Screw Spline Drill Fixture for  
Vertical Fabrication

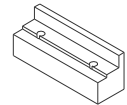

**DJ22**

Dead Load Support Pin  
Drill Fixture

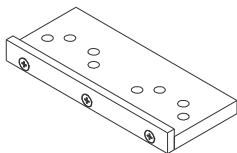

**DJ23**

Shear Block Drill Fixture for  
4 1/2" Center-Set Horizontals

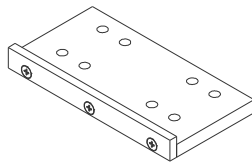

**DJ24**

Shear Block Drill Fixture for  
4 1/2" Offset Horizontals

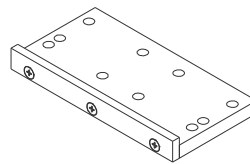

**DJ25**

Screw Spline Drill Fixture for  
4 1/2" Center Set & Offset  
Horizontals

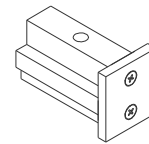

**DJ26**

Shear Block Drill Fixture for  
4 1/2" Horizontals  
(Center-Set & Offset)

# SECTION II: Parts Identification Chart

Drawings on this page are not to scale.

## Misc. Parts:

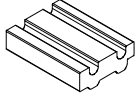

**HN44**  
Head & Sill Foam  
Splice Joint

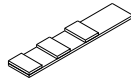

**K898**  
Sill Splice Plates (2)  
per Splice Required

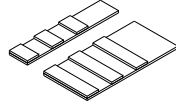

**K898/K897**  
Head Splice Plates



**LB77**  
Vinyl Pocket Filler  
Glass Pockets @  
Perimeter Condition

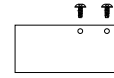

**KN11**  
Structural Glaze  
Head End-Dam  
Package

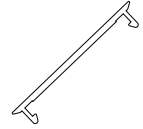

**LB89**  
Vinyl Offset Pocket  
Filler @ Perimeter  
Condition  
Use W/8353

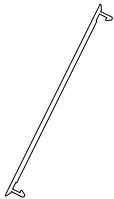

**LB90**  
Vinyl Center-Set Pocket  
Filler @ Perimeter  
Condition  
Use W/8355, 8356, 8361

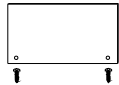

**K941**  
Subsill End-Dam  
Package  
Use w/2S44 Subsill

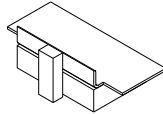

**K895**  
Horizontal Bridge  
Assembly



**HWD1**  
Water Deflector @  
Intermediate Horizontal



**FW33**  
90° Structural  
Glaze Corner  
Water Diverter

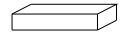

**HCW6**  
Weep Baffle used  
@ Subsill



**WM01**  
Bond Breaker Tape  
4" X .062"  
Used @ Subsill Splices



**HN50**  
1/2" Anti Walk Block  
Use w/8349, 8353,  
8357 & 8361



**HN52**  
5/8" Anti Walk Block  
Use w/8354, 8355,  
& 8359

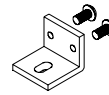

**K473**  
Vertical Anchor  
Package Used with  
Offset Glazed  
Verticals

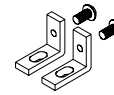

**K992**  
Vertical Anchor  
Package Used with  
Center-Set Glazed  
Verticals

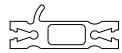

**H260**  
2-Piece Rolled/Slope  
Frame Clips

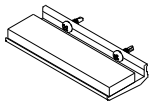

**KN93**  
2-Piece Rolled  
Horizontal Setting  
Chair  
Use w/ 16C9 & 16C7



**FWB6**  
Adjustable Side Lite  
Dead Load Support  
Tube Washer

## SECTION III: Fabrication

### A. Drilling Template Offset Screw Spline Verticals (Offset Mullion)

Left Hand Mullion Shown, Right Hand Opposite

Use the exterior edge of the vertical to align Drill Jig DJ15. Use .221 dia. (#2) drill at darkened areas only.

These preps work for both inside and outside glazed versions.

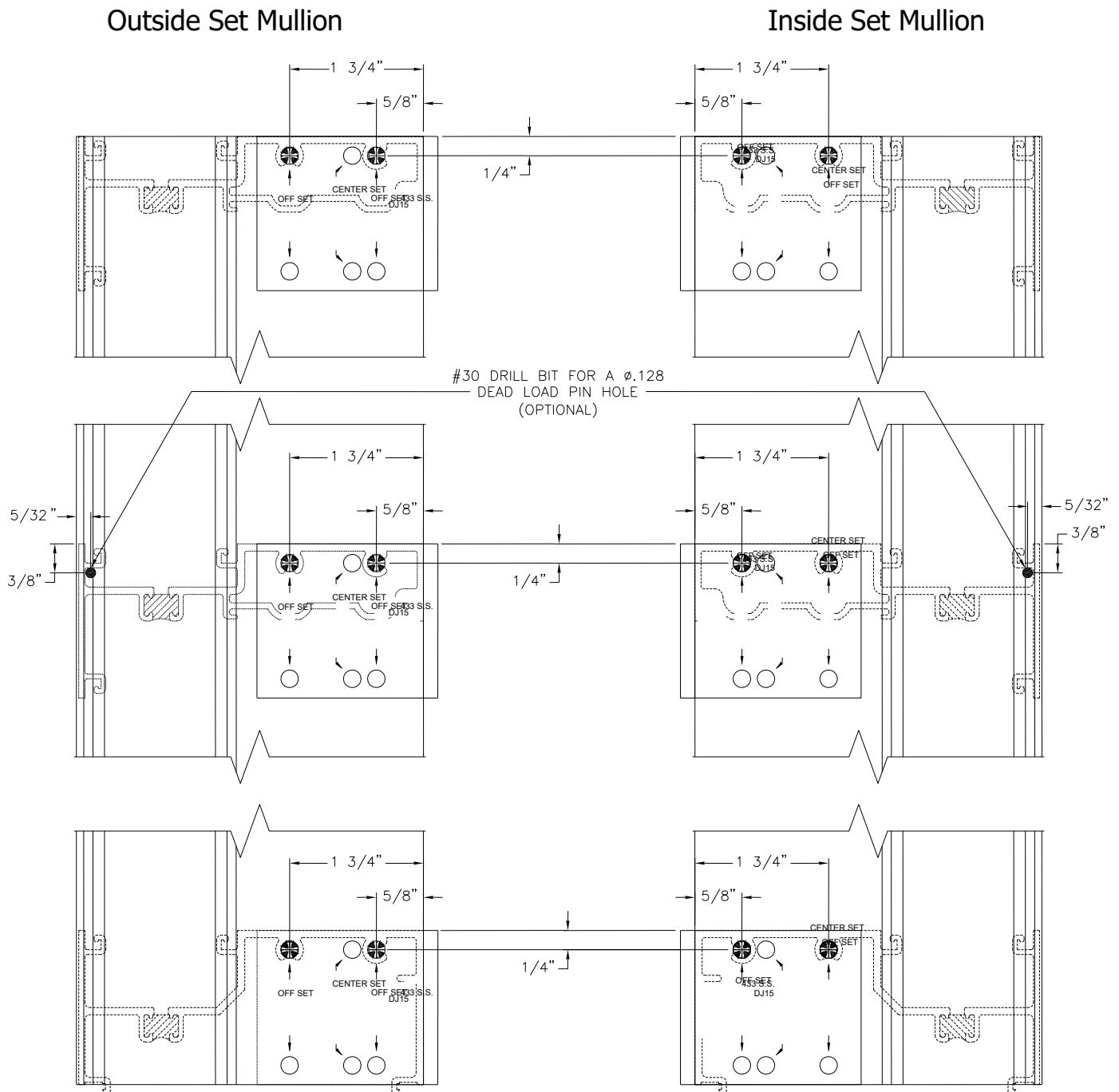

## SECTION III: Fabrication

### A. Drilling Template Offset Screw Spline Verticals (Offset Mullion Filler)

Left Hand Mullion Filler Shown, Right Hand Opposite

Use the exterior edge of the vertical to align Drill Jig DJ15. Use .221 dia. (#2) drill at darkened areas only.

These preps work for both inside and outside glazed versions.

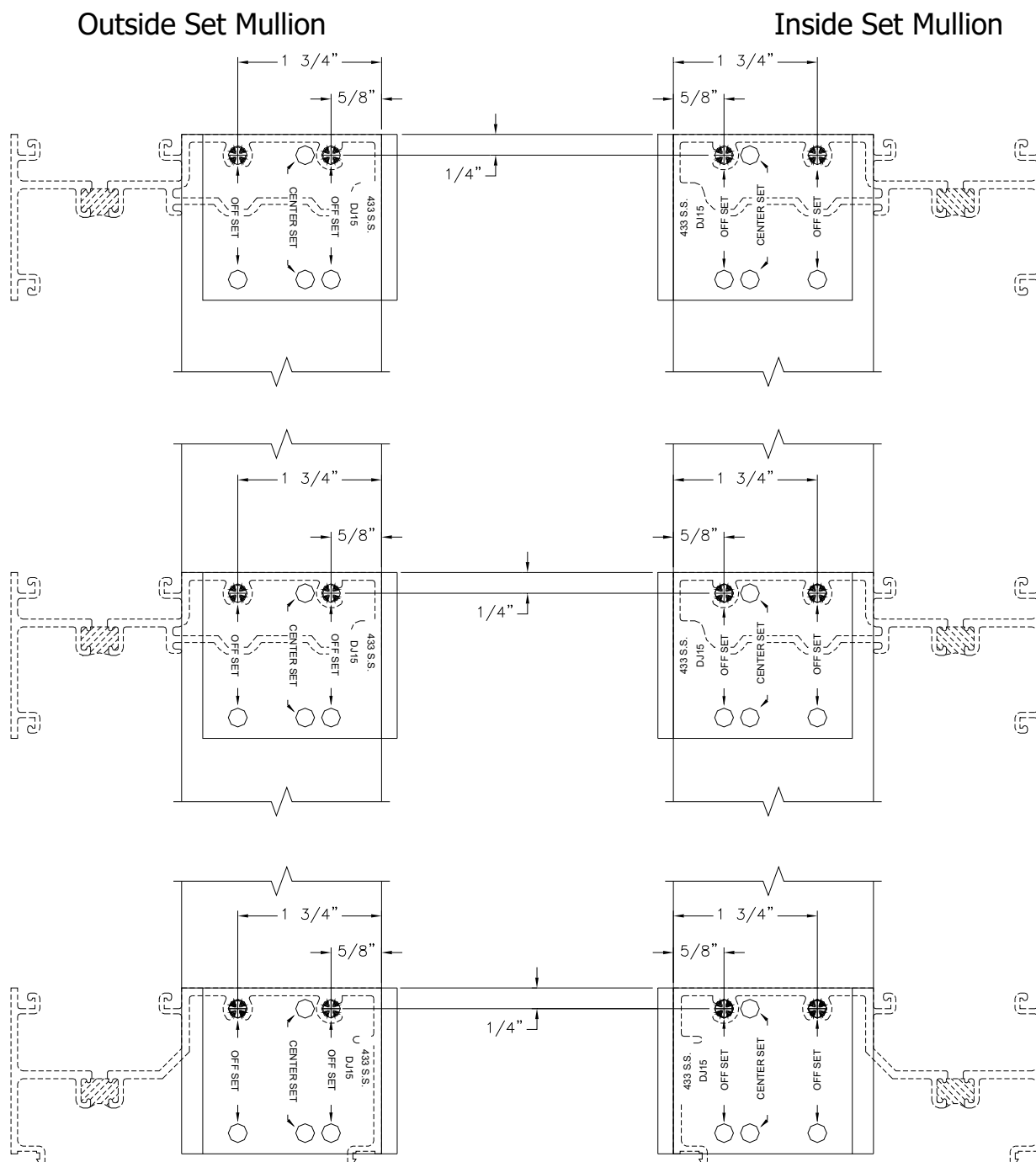

## SECTION III: Fabrication

### A. Drilling Template Offset Screw Spline Verticals (Offset Mullion) with 4 1/2" Horizontals Left Hand Mullion Shown, Right Hand Opposite

Use the exterior edge of the vertical to align Drill Jig DJ25. Use .221 dia. (#2) drill at darkened areas only.

These preps work for both inside and outside glazed versions.

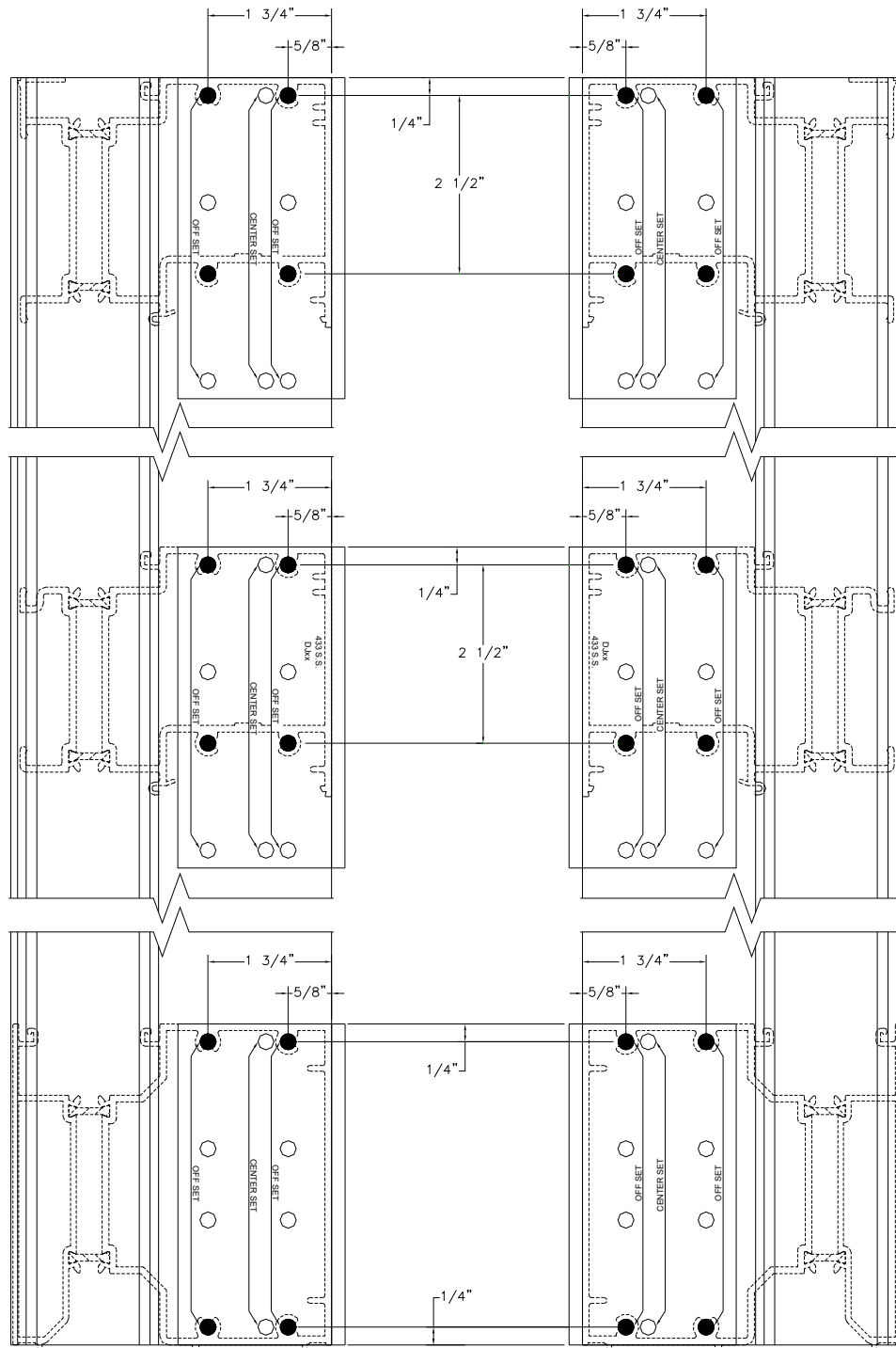

## SECTION III: Fabrication

### B. Drilling Template Offset Shear Block Verticals (Offset Mullion)

Left Hand Mullion Shown, Right Hand Opposite

Use the exterior edge of the vertical to align Drill Jig DJ14. Use .182 dia. (#14) drill at darkened areas only.

These preps work for both inside and outside glazed versions.

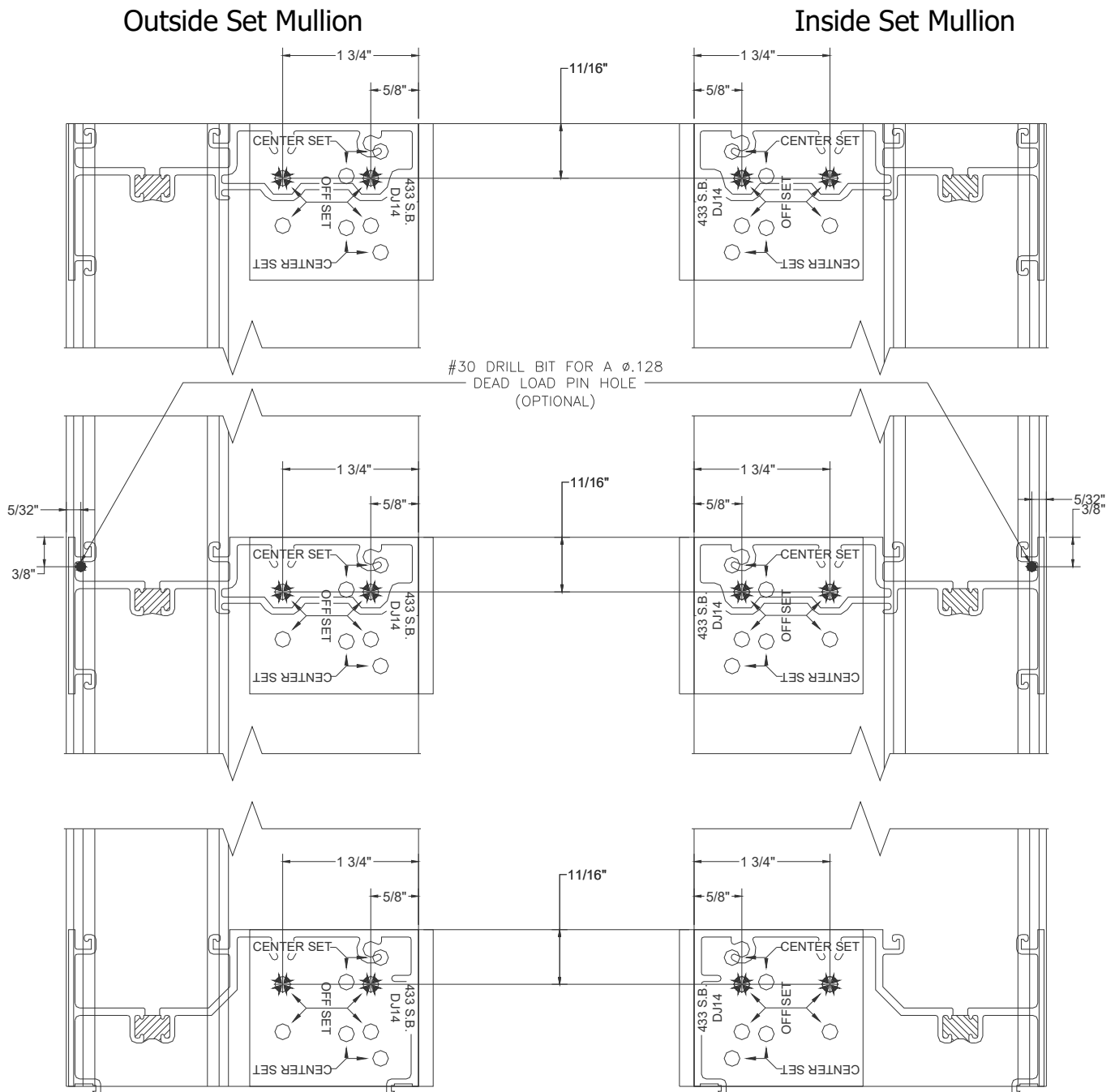

## SECTION III: Fabrication

### B. Drilling Template Offset Shear Block Verticals (Offset Mullion Filler)

Left Hand Mullion Shown, Right Hand Opposite

Use the exterior edge of the vertical to align Drill Jig DJ14. Use .182 dia. (#14) drill at darkened areas only.

These preps work for both inside and outside glazed versions.

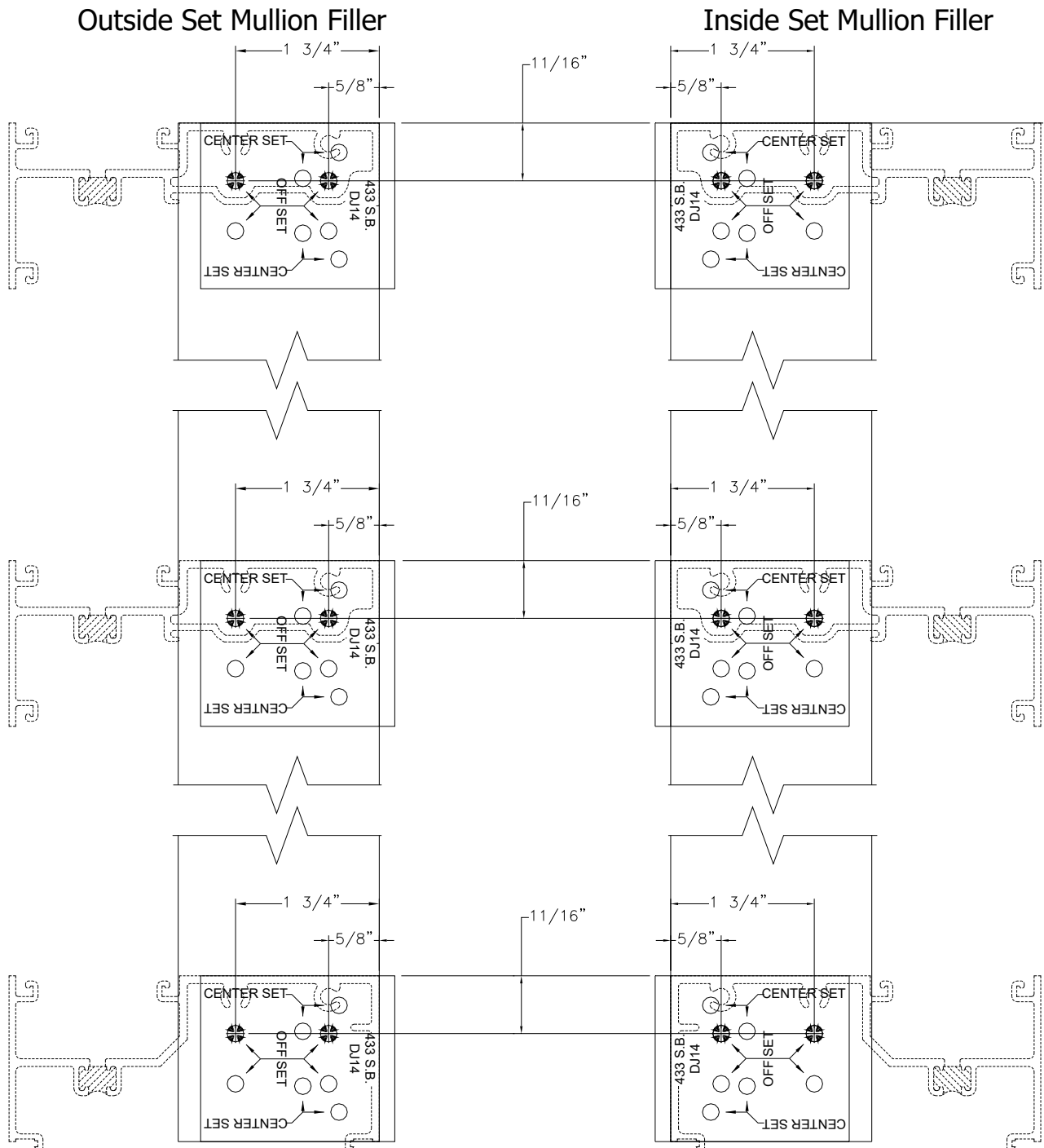



## SECTION III: Fabrication

### B. Drilling Template Offset Shear Block Verticals (Offset Mullion) with 4 1/2" Horizontals Left Hand Mullion Shown, Right Hand Opposite

Use the exterior edge of the vertical to align Drill Jig DJ24. Use .182 dia. (#14) drill at darkened areas only.

These preps work for both inside and outside glazed versions.

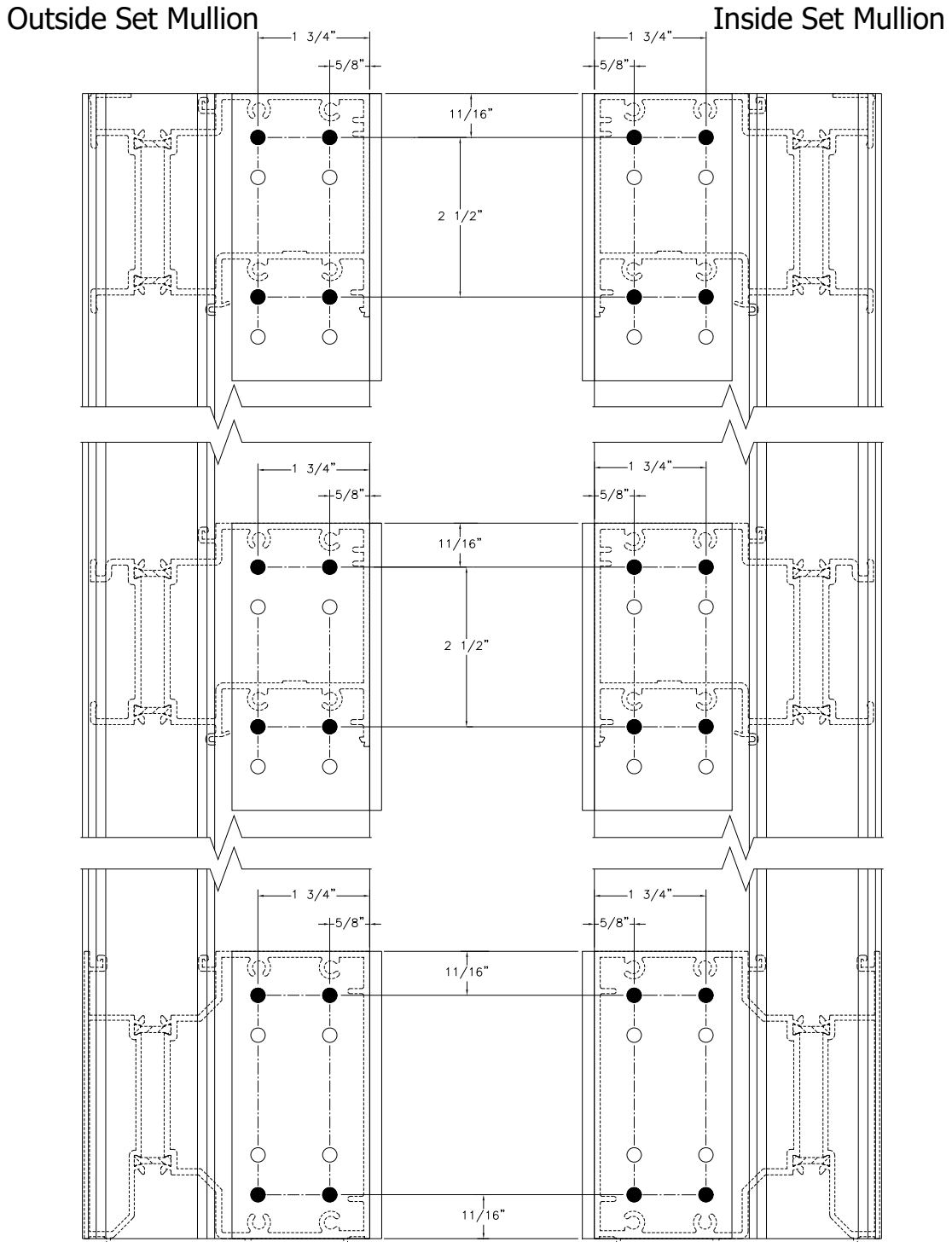

## SECTION III: Fabrication

### C. Drilling Template Center-Set Screw Spline Verticals (Center-Set Mullion)

Left Hand Mullion Shown, Right Hand Opposite

Use the exterior edge of the vertical to align Drill Jig DJ15. Use .221 dia. (#2) drill at darkened areas only.

These preps work for both inside and outside glazed versions.

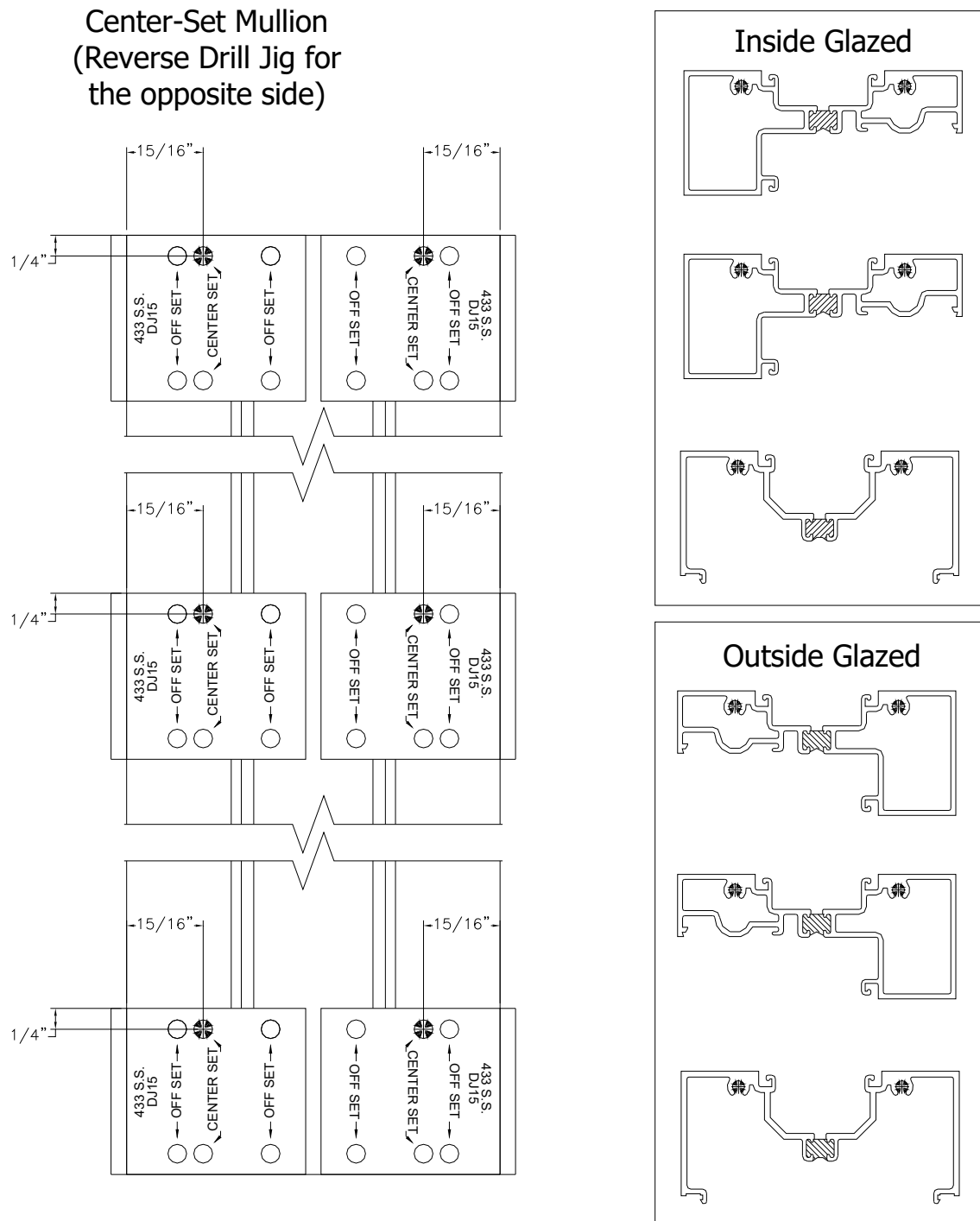

## **SECTION III: Fabrication**

### **C. Drilling Template Center-Set Screw Spline Verticals (Center-Set Mullion) with 4 1/2" Horizontals**

**Left Hand Mullion Shown, Right Hand Opposite**

Use the exterior edge of the vertical to align Drill Jig DJ25. Use .221 dia. (#2) drill at darkened areas only.

These preps work for both inside and outside glazed versions.

**Center-Set Mullion  
(Reverse Drill Jig for  
the opposite side)**

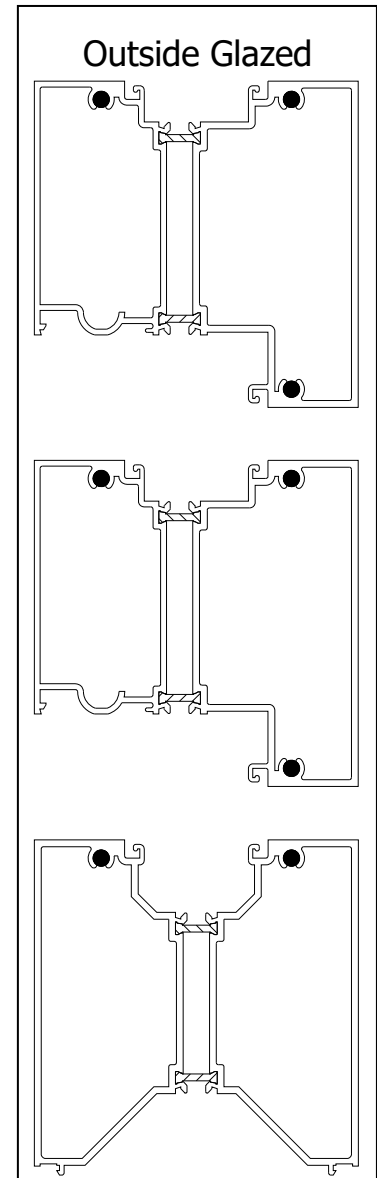
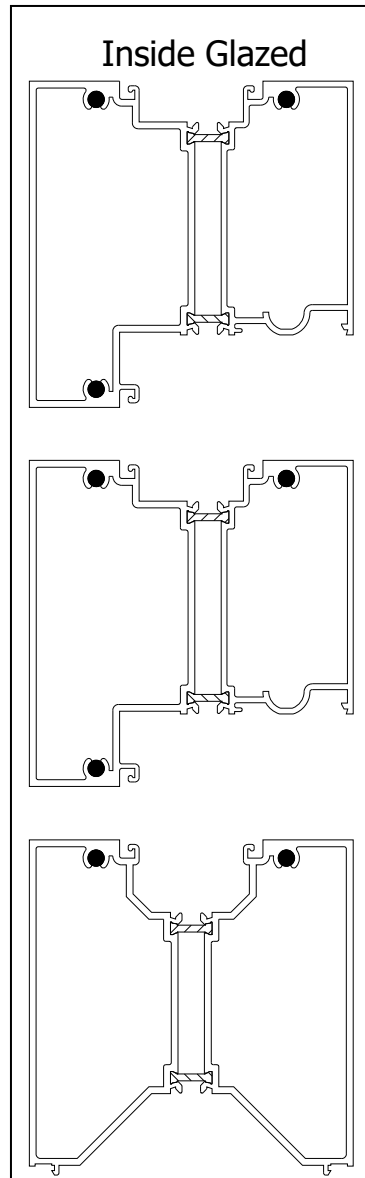
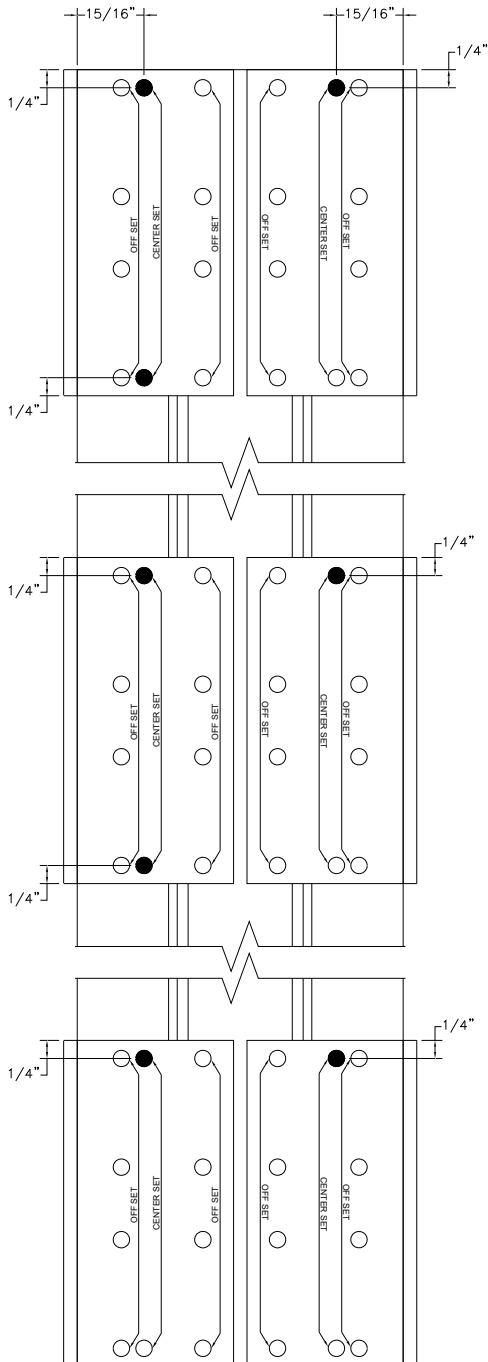

## SECTION III: Fabrication

### D. Drilling Template Center-Set Shear Block Verticals (Center-Set Mullion)

Left Hand Mullion Shown, Right Hand Opposite

Use the exterior edge of the vertical to align Drill Jig DJ14. Use .182 dia. (#14) drill at darkened areas only.

These preps work for both inside and outside glazed versions.

Center-Set Mullion  
(Reverse Drill Jig for  
the opposite side)

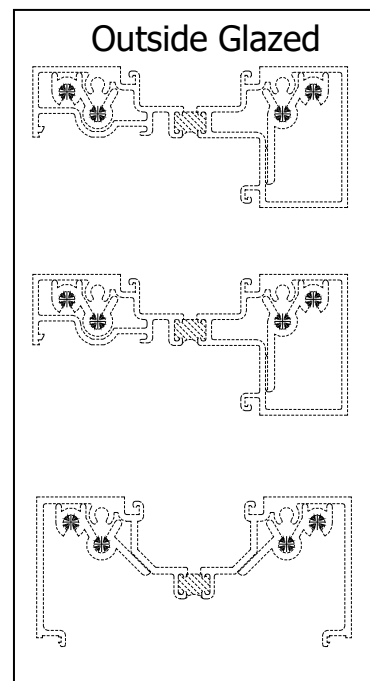
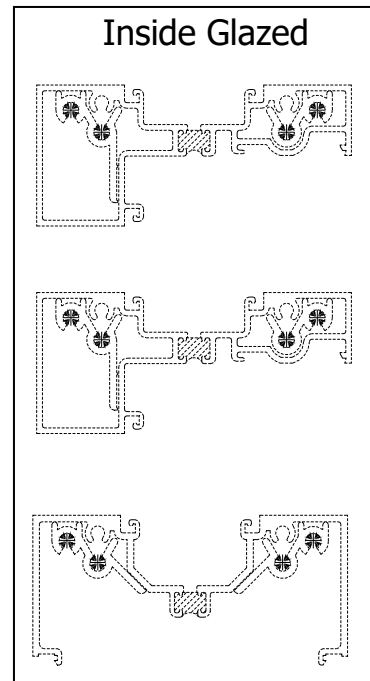
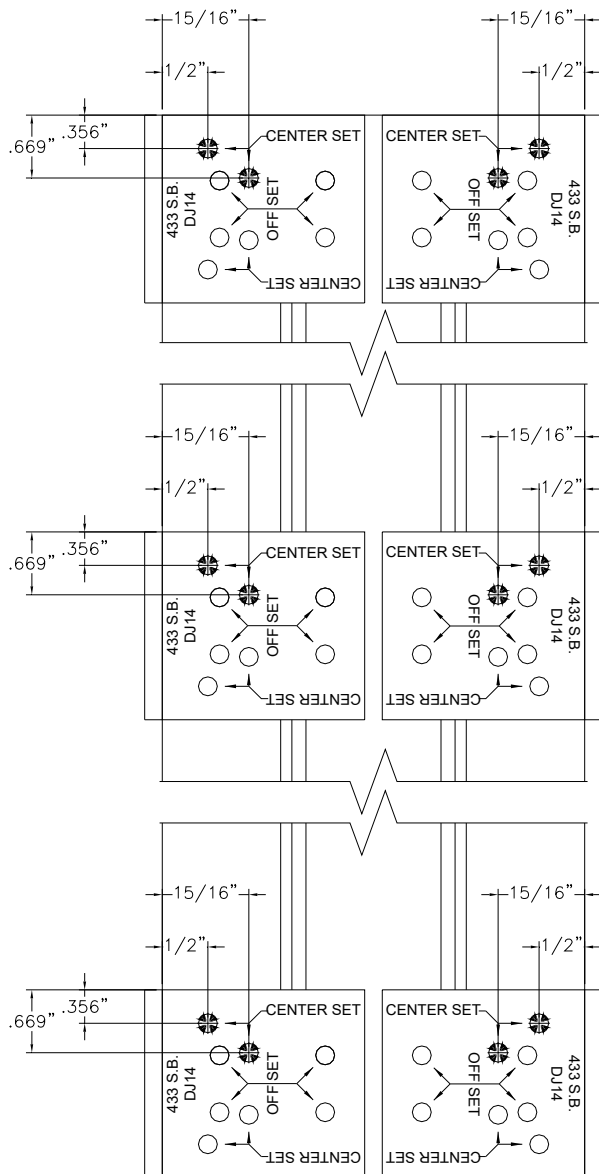

## SECTION III: Fabrication

### D. Drilling Template Center-Set Shear Block Verticals (Center-Set Mullion) with 4 1/2" Horizontals

Left Hand Mullion Shown, Right Hand Opposite

Use the exterior edge of the vertical to align Drill Jig DJ23. Use .182 dia. (#14) drill at darkened areas only.

These preps work for both inside and outside glazed versions.

Center-Set Mullion  
(Reverse Drill Jig for  
the opposite side)

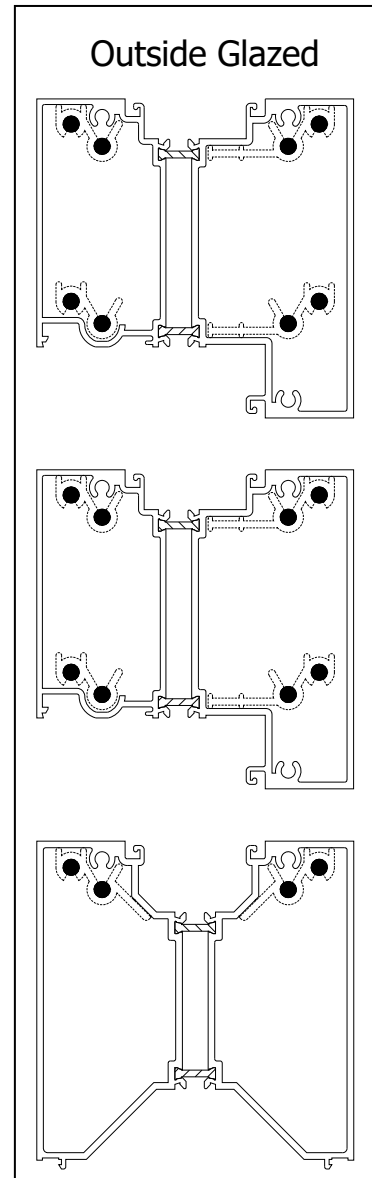
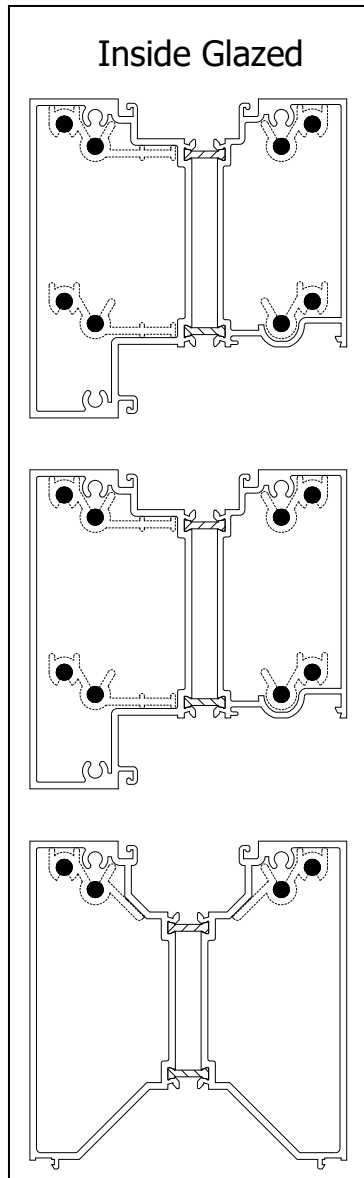
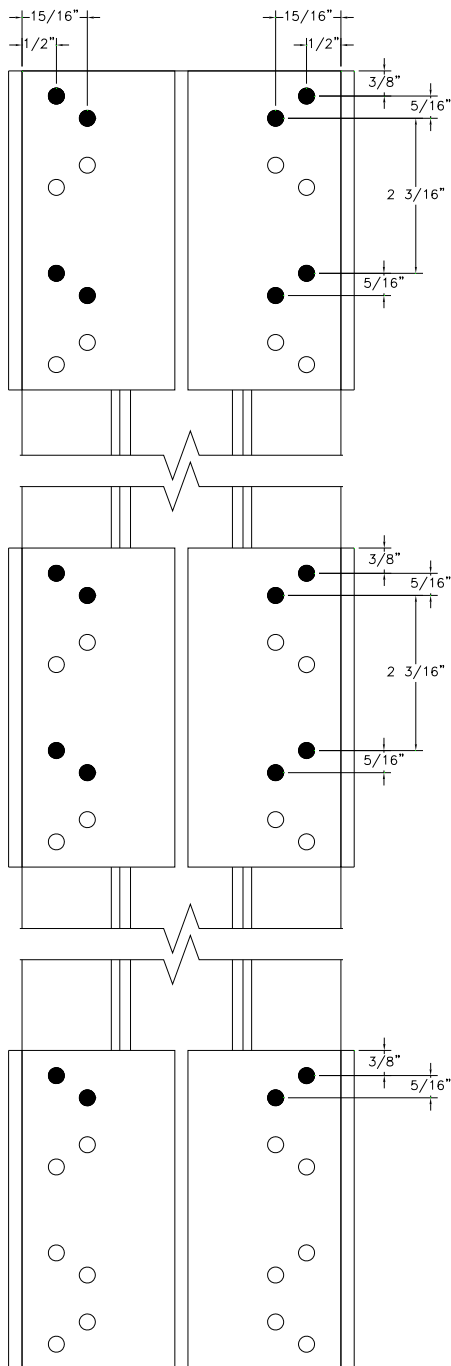

## SECTION III: Fabrication

### D. Drilling Template Center-Set Shear Block Verticals & Horizontals (2-Piece Slope or Arch Top) Left Hand Mullion Shown, Right Hand Opposite

Vertical Fabrication:  
Outside Glazed Shown  
Inside Opposite

Use .147 dia. (#26) drill at darkened areas only. These preps work for both inside and outside glazed versions.

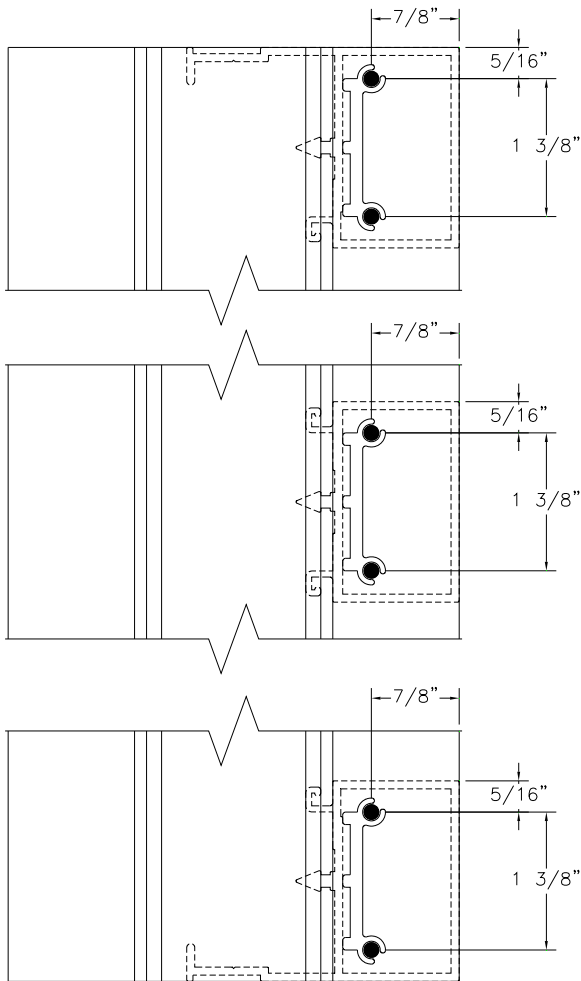

Horizontal Fabrication

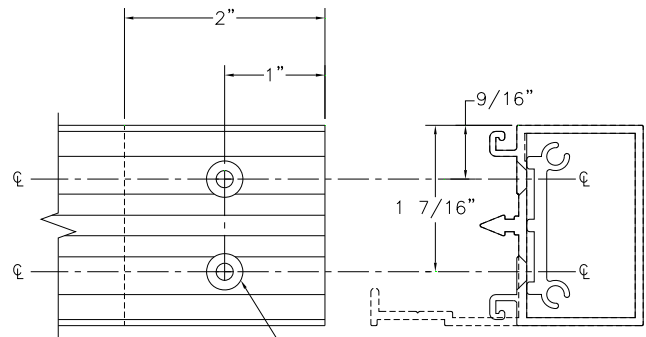

**3/16" Dia. Thru Hole  
(1) Wall.  
Countersink For  
#8 Flat Head Screw  
Thru (1) Wall  
(2) Holes Each End**

## SECTION III: Fabrication

### E. Drilling Template Offset @ 90° Corner Horizontal/Head/Sill

Use .246 Diameter (#D) Drill Bit

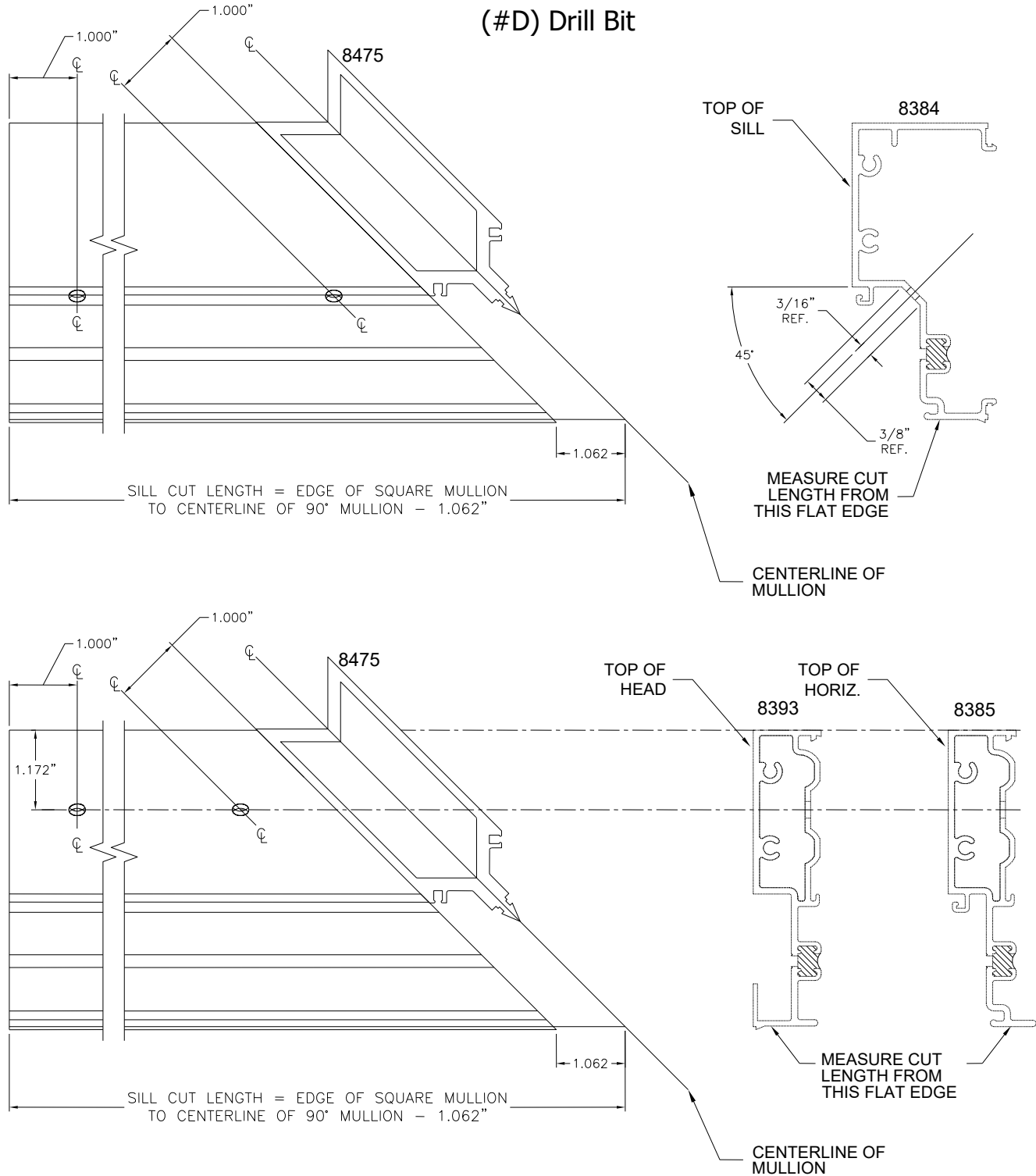

## SECTION III: Fabrication

### E. Drilling Template Offset @ 90° Corner Horizontal/Head/Sill 4 1/2" Horizontals

Use .246 Diameter  
(#D) Drill Bit

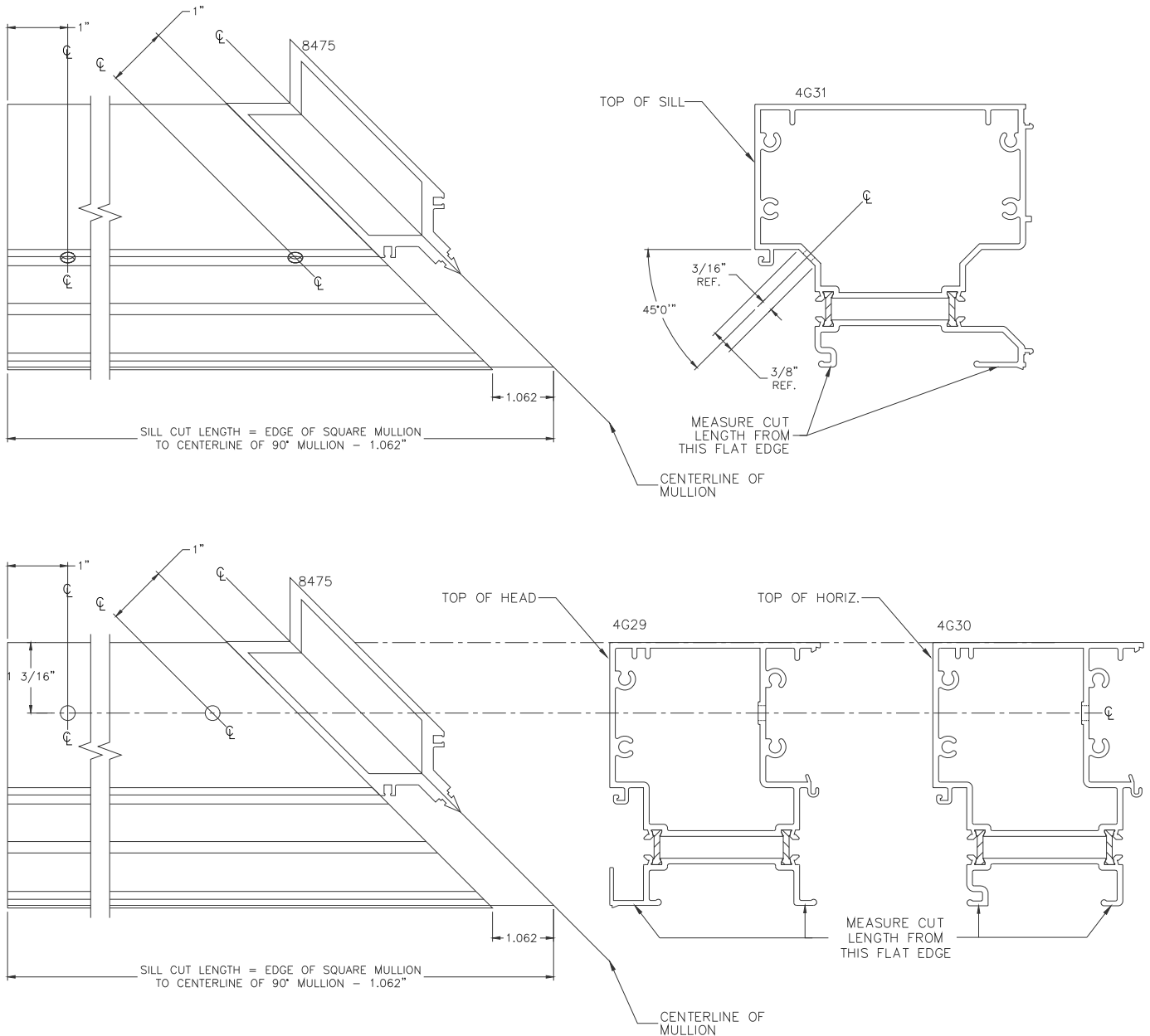



## **SECTION III: Fabrication**

### **F. Drilling Template for Offset and Center-Set Shear Block at Sills**

Fixture DJ13 should be placed at the end of the sills as shown. These preps work on all offset and center-set sills.

Use .246 Diameter (#D) Drill Bit

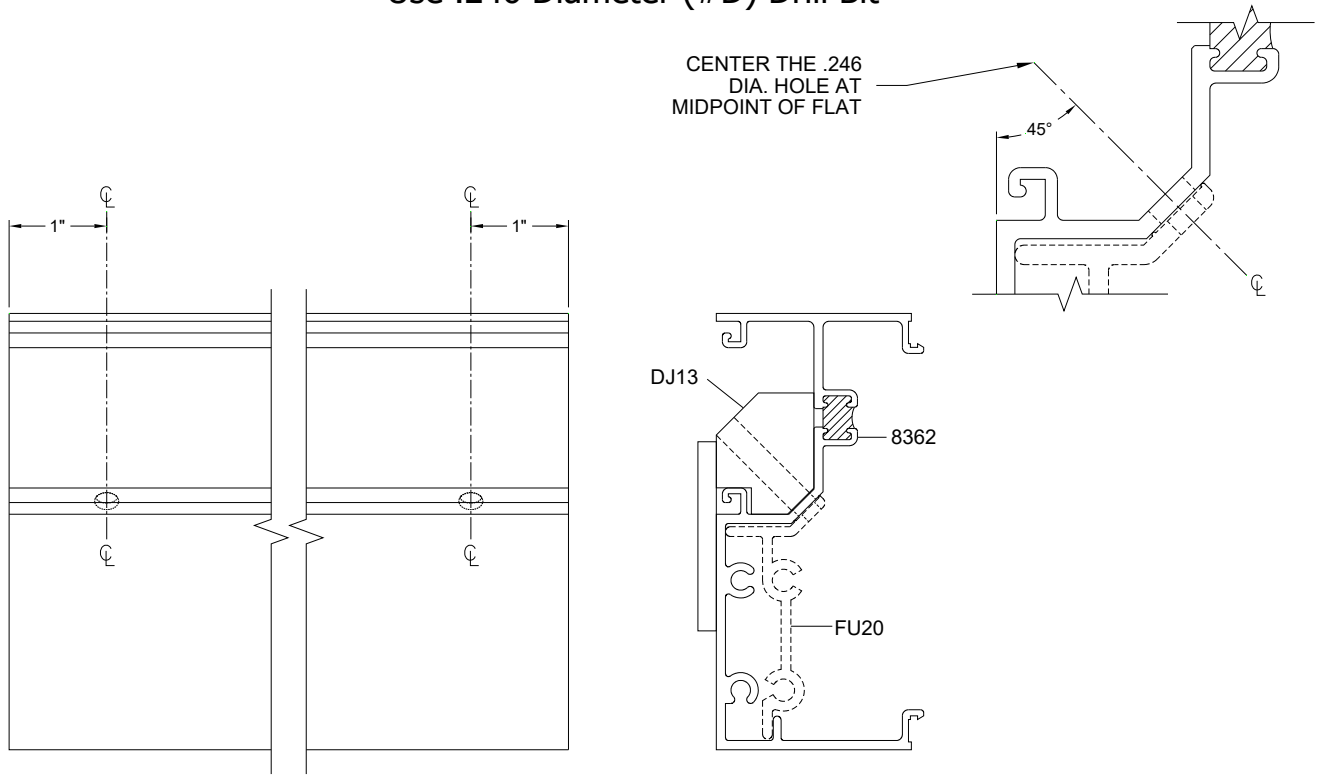

(Typ. at each end)

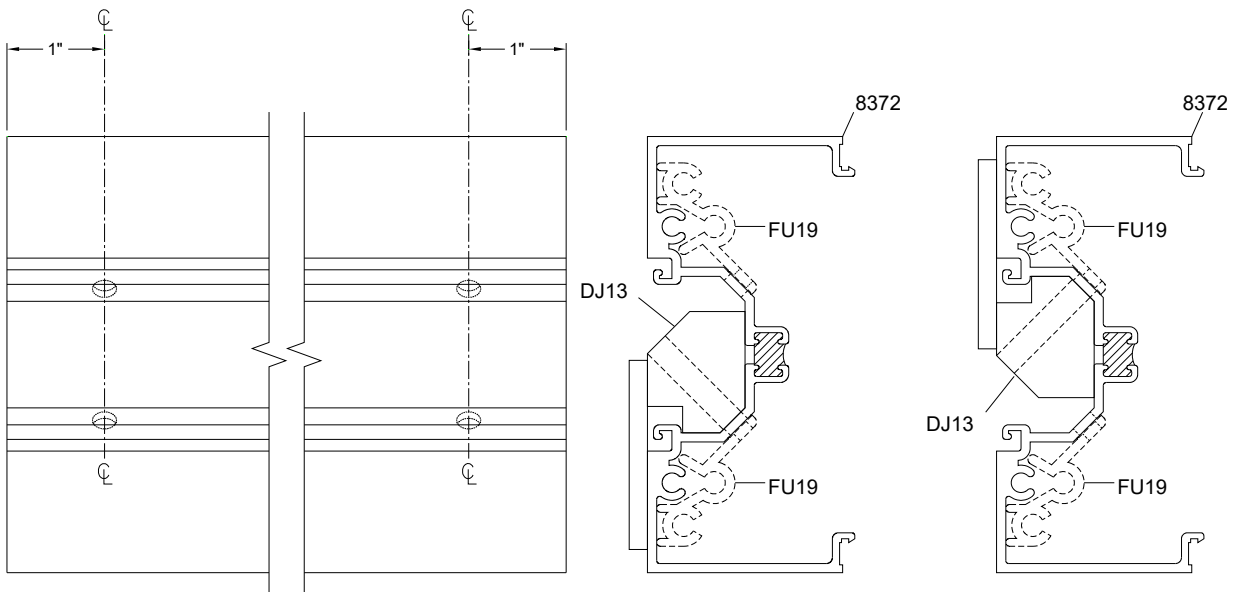

Drill one side and flip the fixture to drill the opposite side.  
(Typ. at each end)

## SECTION III: Fabrication

### F. Drilling Template for Offset and Center-Set Shear Block at 4 1/2" Sills

Fixture DJ13 should be placed at the end of the sills as shown. These preps work on all offset and center-set sills.

Use .246 Diameter (#D) Drill Bit

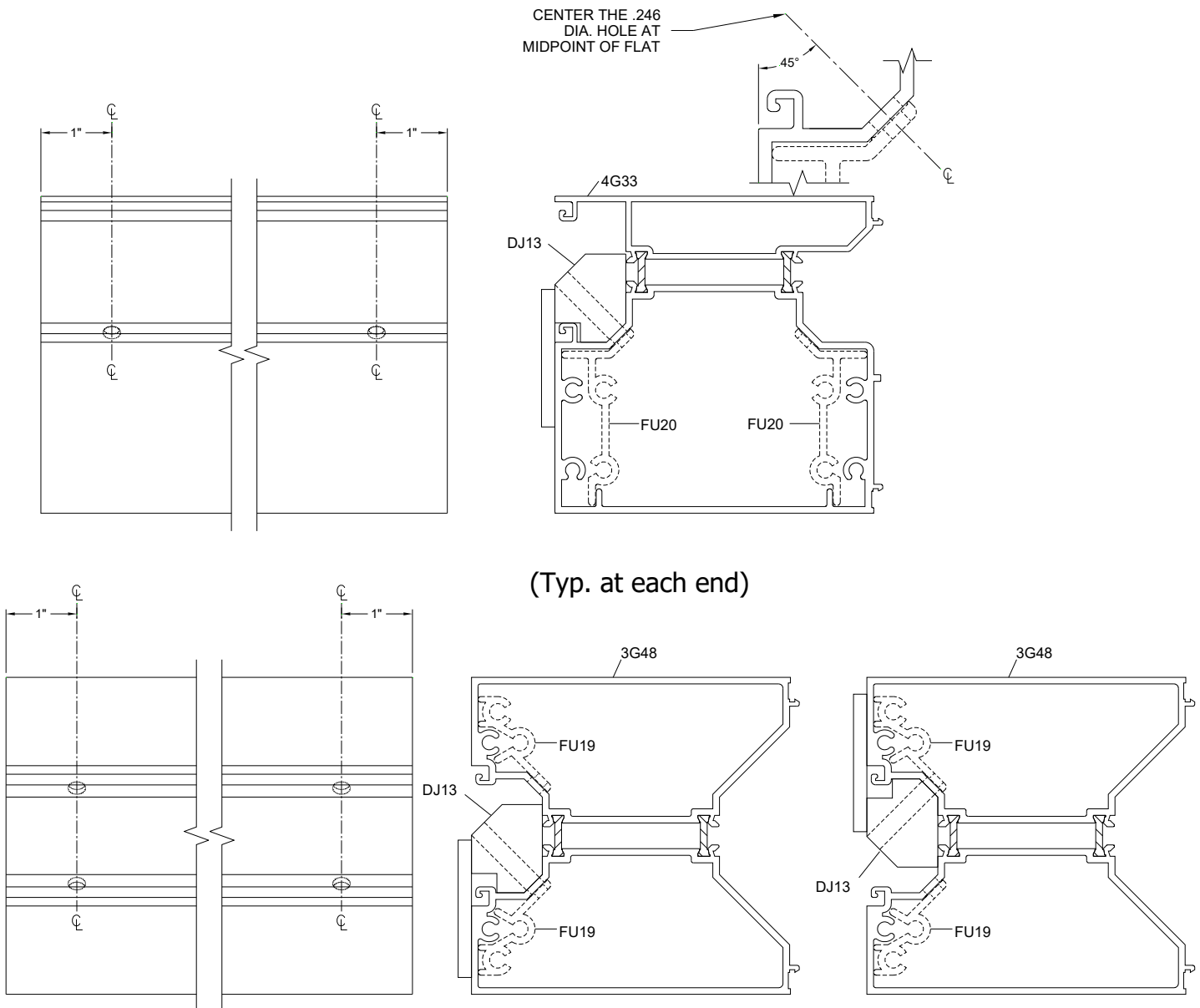

## SECTION III: Fabrication

### G. Drilling Template Offset and Center-Set Shear Block at Horizontals

Fixture DJ12 is self-aligning and should be placed at the end of the horizontal as shown. These preps work on all offset head and intermediate horizontals.

Use .246 Diameter (#D) Drill Bit

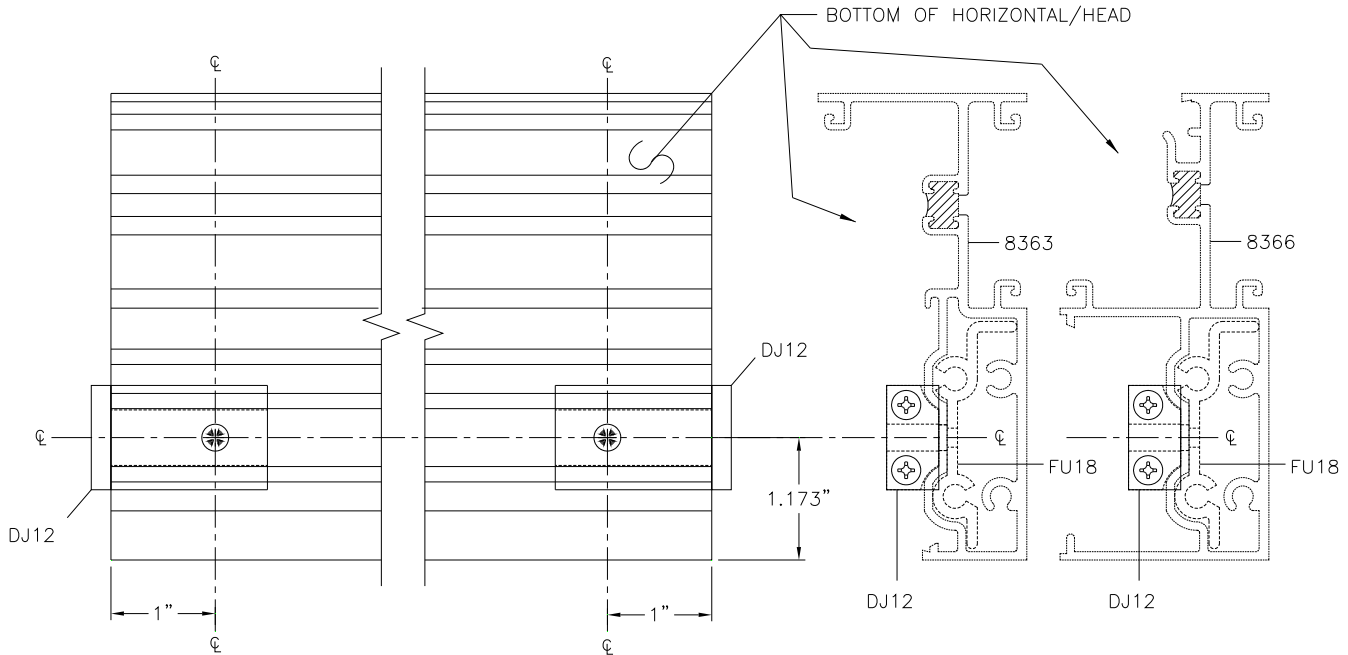

Fixture DJ13 should be placed at the end of the horizontal as shown. These preps work on all center-set head and intermediate horizontals.

Use .246 Diameter (#D) Drill Bit

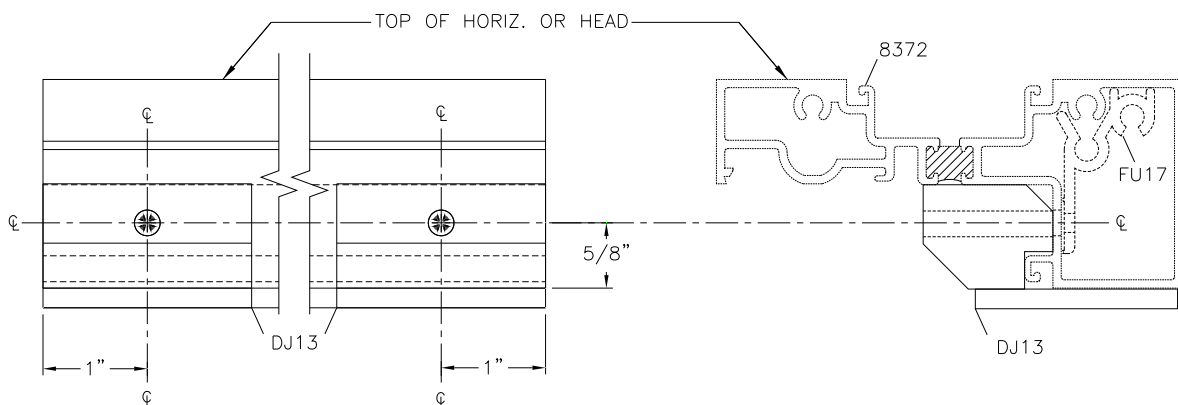

## SECTION III: Fabrication

### G. Drilling Template Offset and Center-Set Shear Block at 4 1/2" Horiz.

Fixture DJ26 is self-aligning and should be placed at the end of the horizontal as shown. These preps work on all offset head and intermediate horizontals.

Use .246 Diameter (#D) Drill Bit

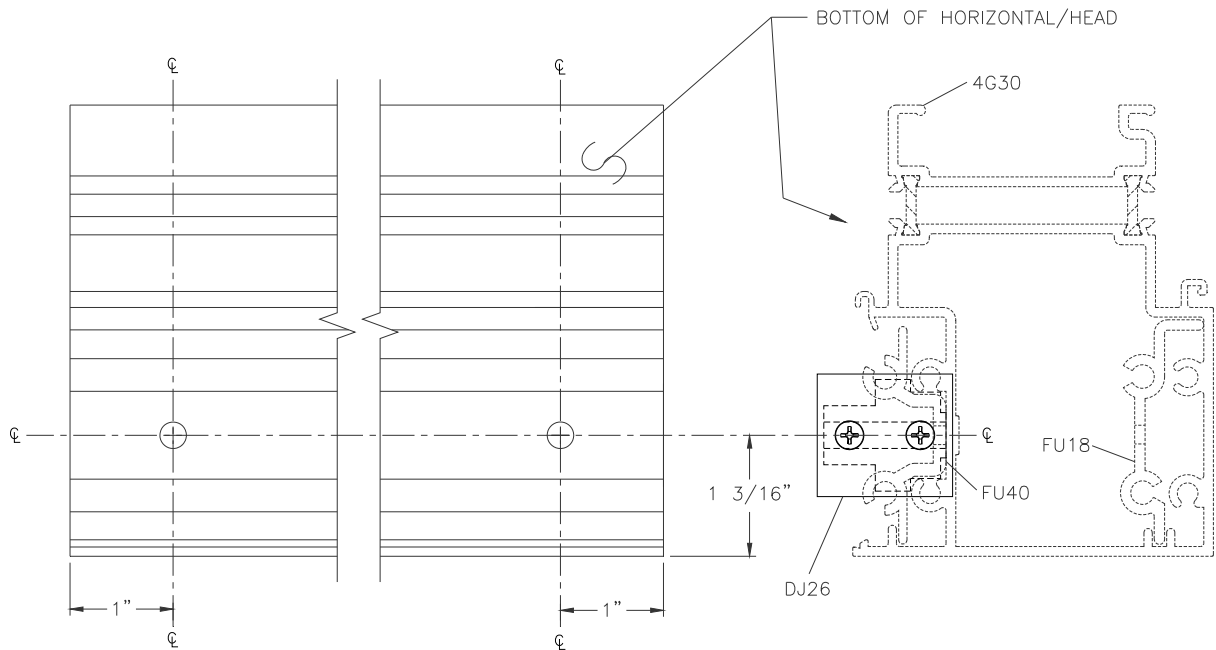

Fixture DJ26 should be placed at the end of the horizontal as shown. These preps work on all center-set head and intermediate horizontals.

Use .246 Diameter (#D) Drill Bit

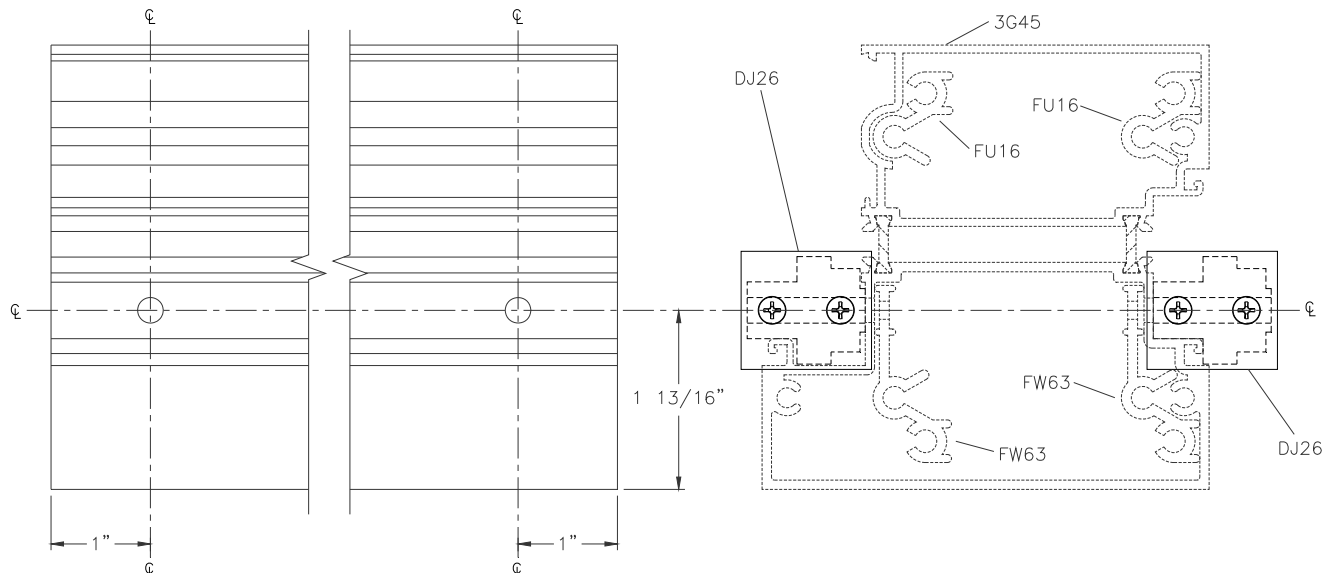

## SECTION III: Fabrication

### H. Drilling Template Offset Glazed Head & Sill Through

#### Head and Sill through Butt Glazed Jamb and Vertical

Use the exterior edge of the jamb or vertical to align drill jig DJ15.

Use .221 diameter (#2) drill bit at darkened areas only.

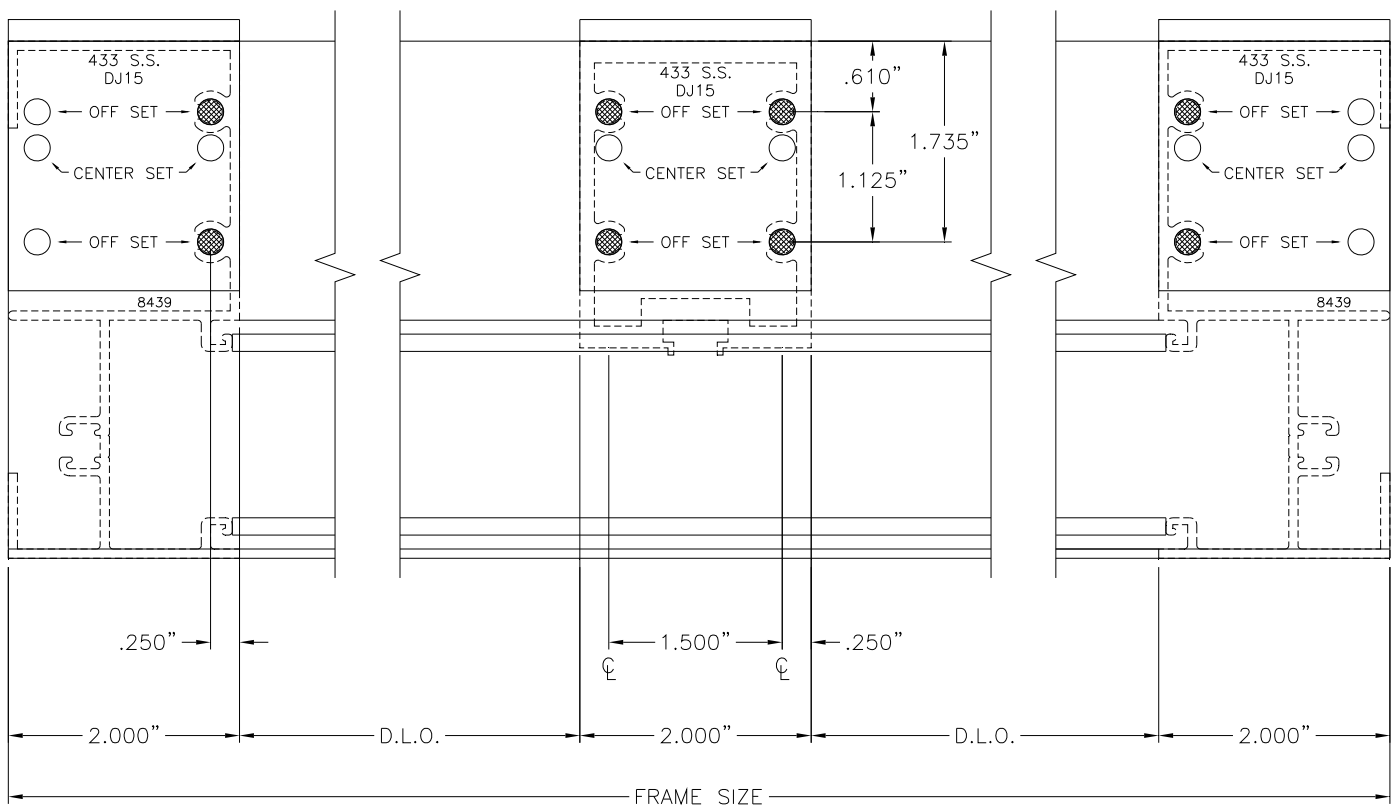

## SECTION III: Fabrication

### H. Drilling Template Offset Screw Spline SSG Verticals for Intermediate Horizontal with Head & Sill Through

Use the exterior edge of the vertical to align Drill Jig DJ15 for 2" mullions and DJ25 for 4 1/2" mullions. Use .221 dia. (#2) drill at darkened areas only.

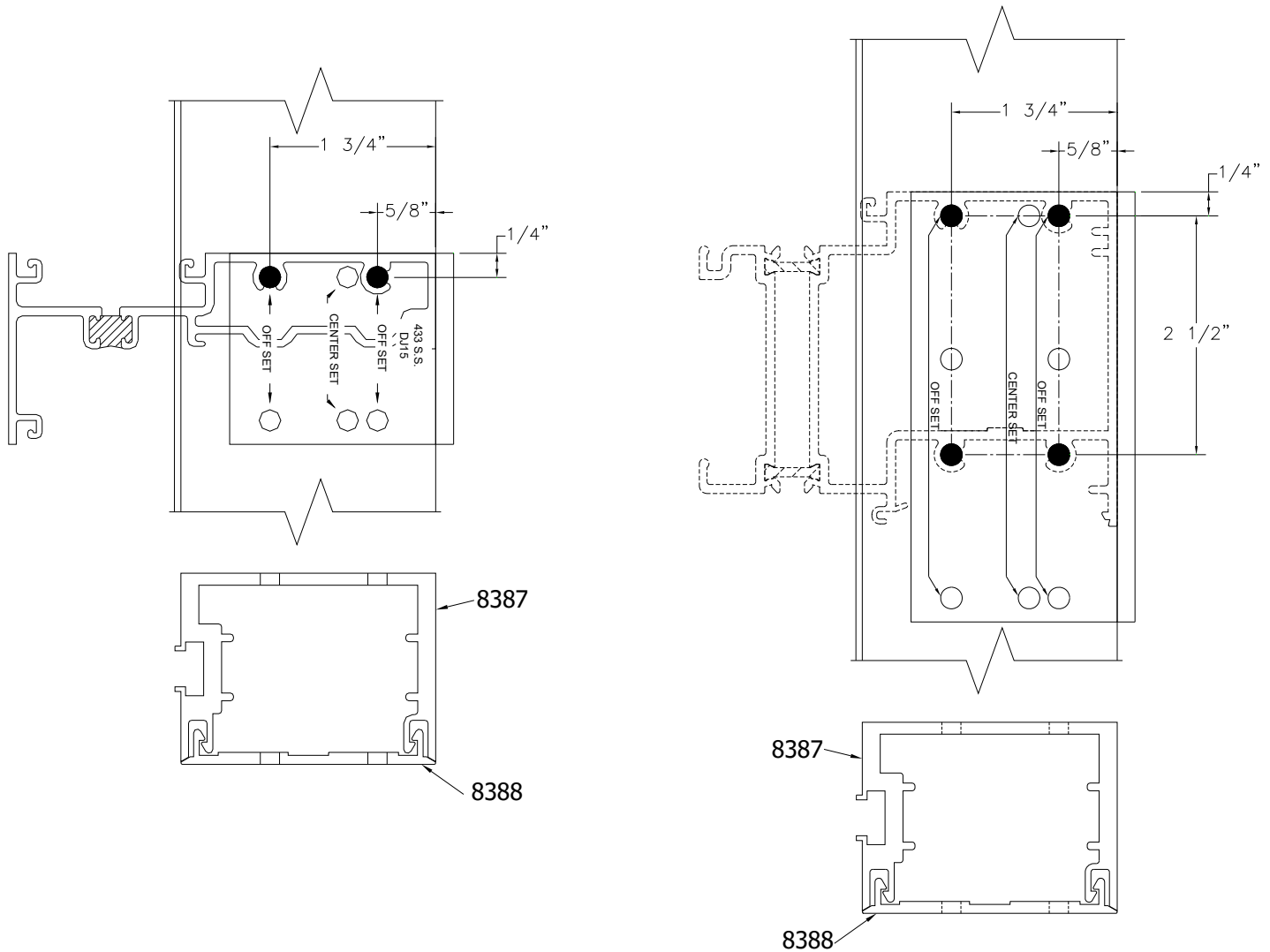

## SECTION III: Fabrication

### H. Drilling Template Offset Shear Block SSG Verticals for Intermediate Horizontal with Head & Sill Through

Use the exterior edge of the vertical to align Drill Jig DJ14 for 2" mullions and DJ24 for 4 1/2" mullions. Use .201 dia. (#7) drill at darkened areas only.

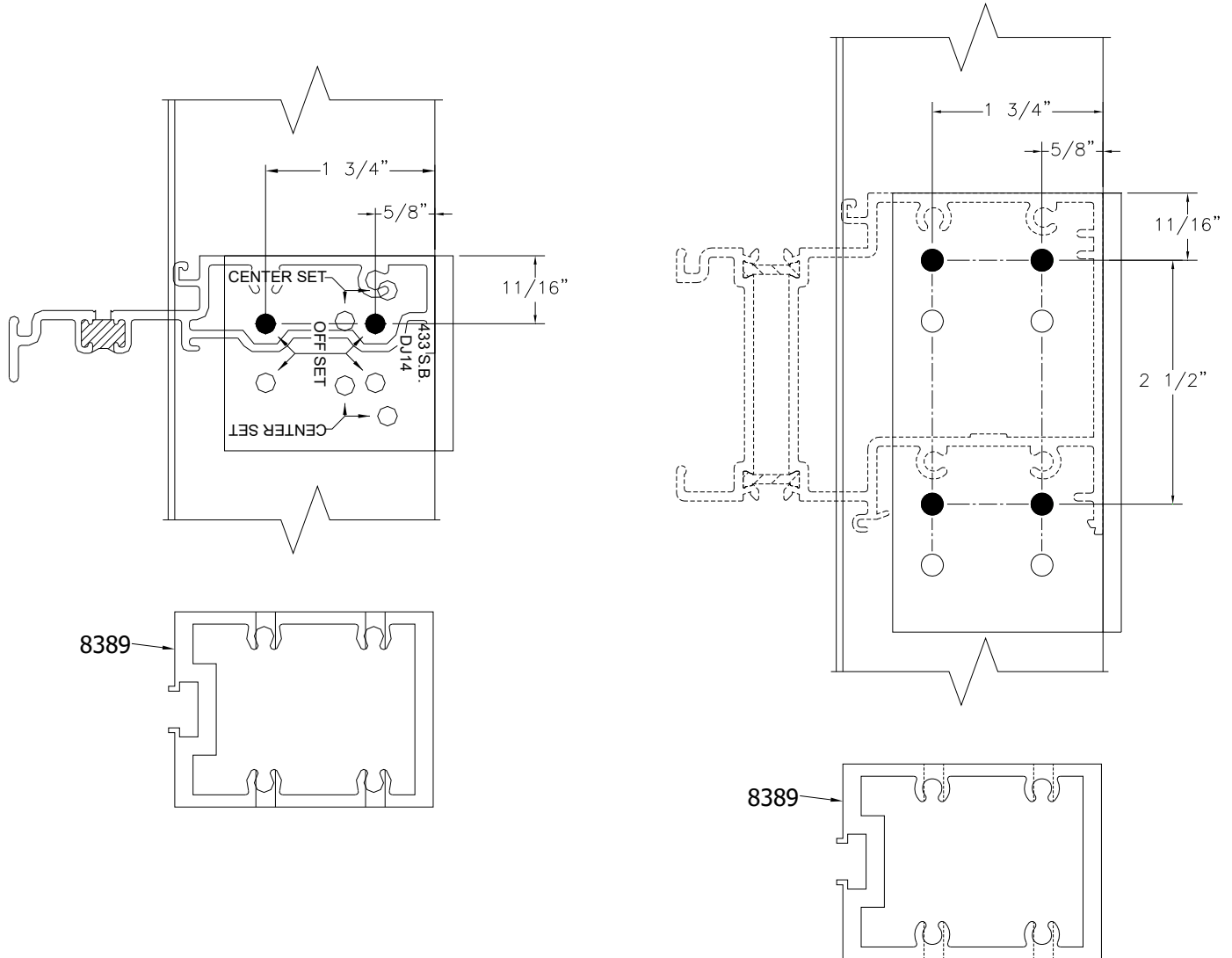

## SECTION IV: Unit Assembly

### A. Screw Spline (Offset and Center-Set)

#### Offset Glazed Assembly

Outside Set, Inside glazed shown,  
Outside Set, Outside Glazed Similar

Note: Wax Type Lubricate may be required @ Assembly Fasteners

4 1/2" Head,  
Horizontal &  
Sill Similar

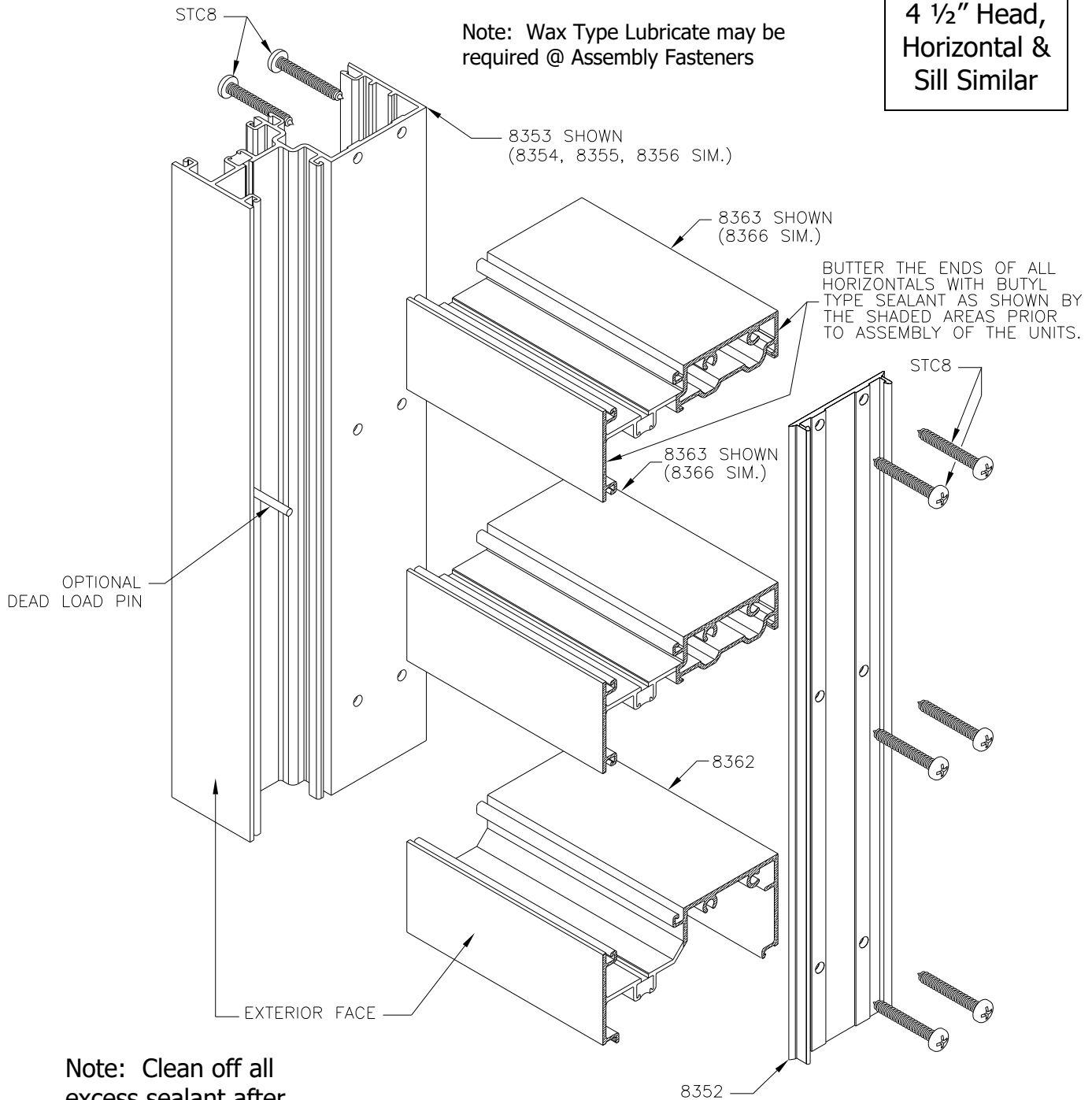

BUTTER THE ENDS OF ALL HORIZONTALS WITH BUTYL TYPE SEALANT AS SHOWN BY THE SHADED AREAS PRIOR TO ASSEMBLY OF THE UNITS.

Note: Clean off all excess sealant after assembly.



## SECTION IV: Unit Assembly

### A. Screw Spline (Offset and Center-Set)

#### Offset Glazed Assembly

Inside Set, Outside glazed shown,  
Inside Set, Inside Glazed Similar

Note: Wax Type Lubricate may be required @ Assembly Fasteners

4 1/2" Head,  
Horizontal &  
Sill Similar

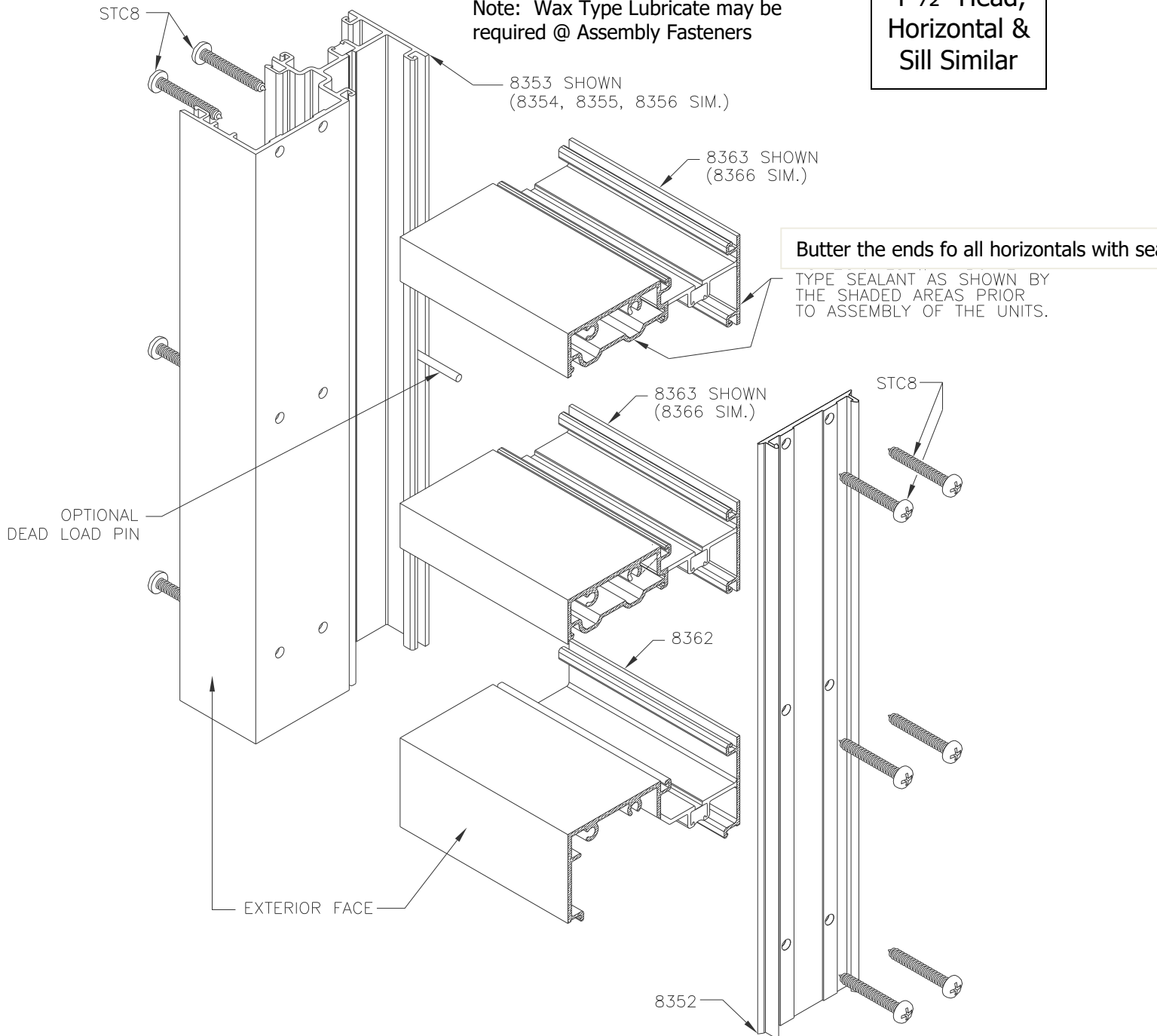

Note: Clean off all excess sealant after assembly.

## SECTION IV: Unit Assembly

### A. Screw Spline (Offset and Center-Set)

#### Offset Glazed Assembly

Inside Set, Outside Glazed shown,  
Inside Set, Inside Glazed Similar

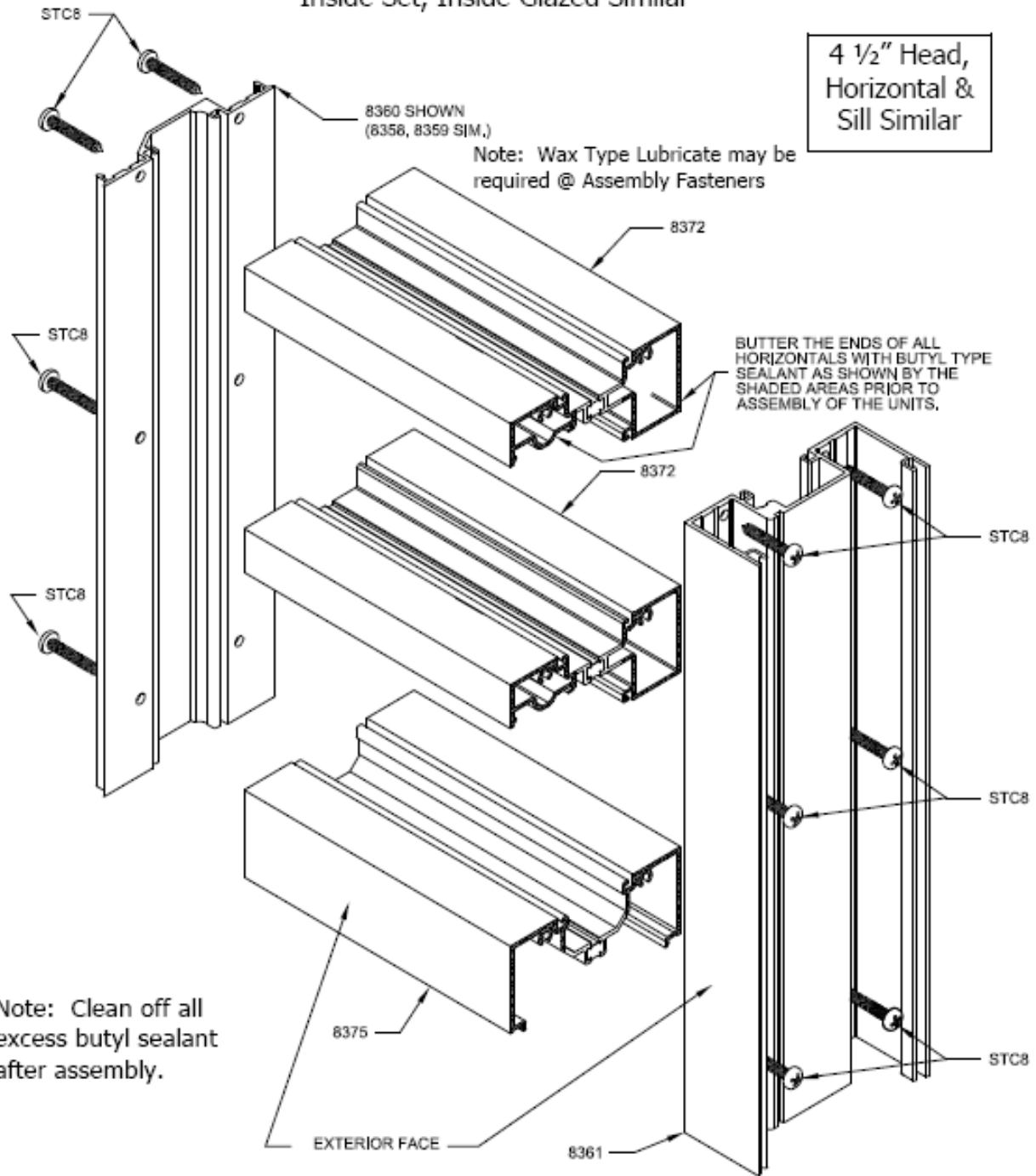

# SECTION IV: Unit Assembly

## A. Screw Spline (Offset and Center-Set)

### Center Glazed Assembly Inside Glazed

8361 SHOWN  
(8358, 8359 SIM.)

STC8

Note: Wax Type Lubricate may be required @ Assembly Fasteners

4 1/2" Head,  
Horizontal &  
Sill Similar

BUTTER THE ENDS OF ALL  
HORIZONTALS WITH BUTYL TYPE  
SEALANT AS SHOWN BY THE  
SHADED AREAS PRIOR TO  
ASSEMBLY OF THE UNITS.

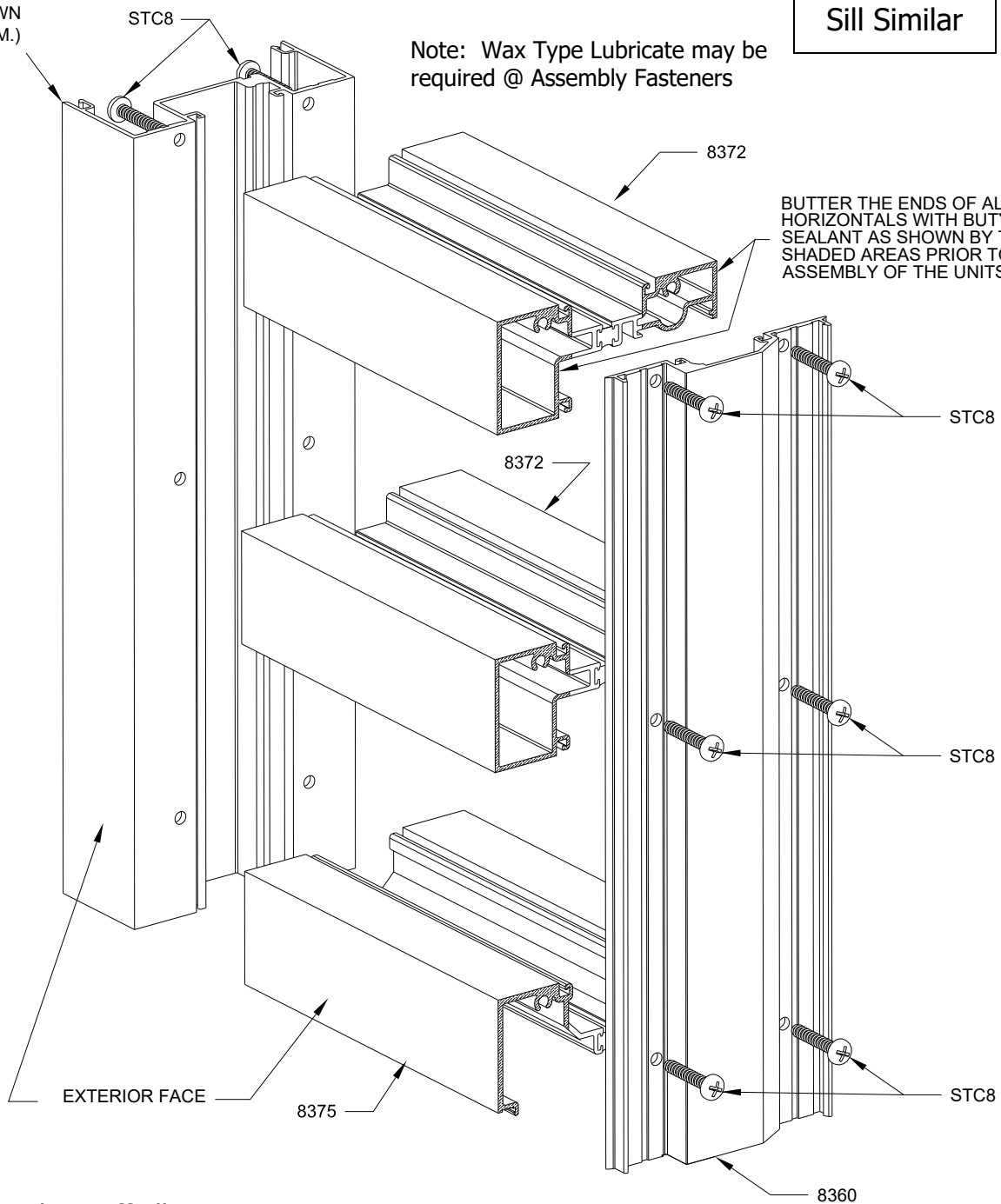

Note: Clean off all  
excess sealant after  
assembly.

# SECTION IV: Unit Assembly

## A. Screw Spline (Offset and Center-Set)

### Offset Structural Glazed Assembly

4 1/2" Head,  
Horizontal &  
Sill Similar

Note: Wax Type Lubricate may be required @ Assembly Fasteners

Details shown without removable face for clarity.

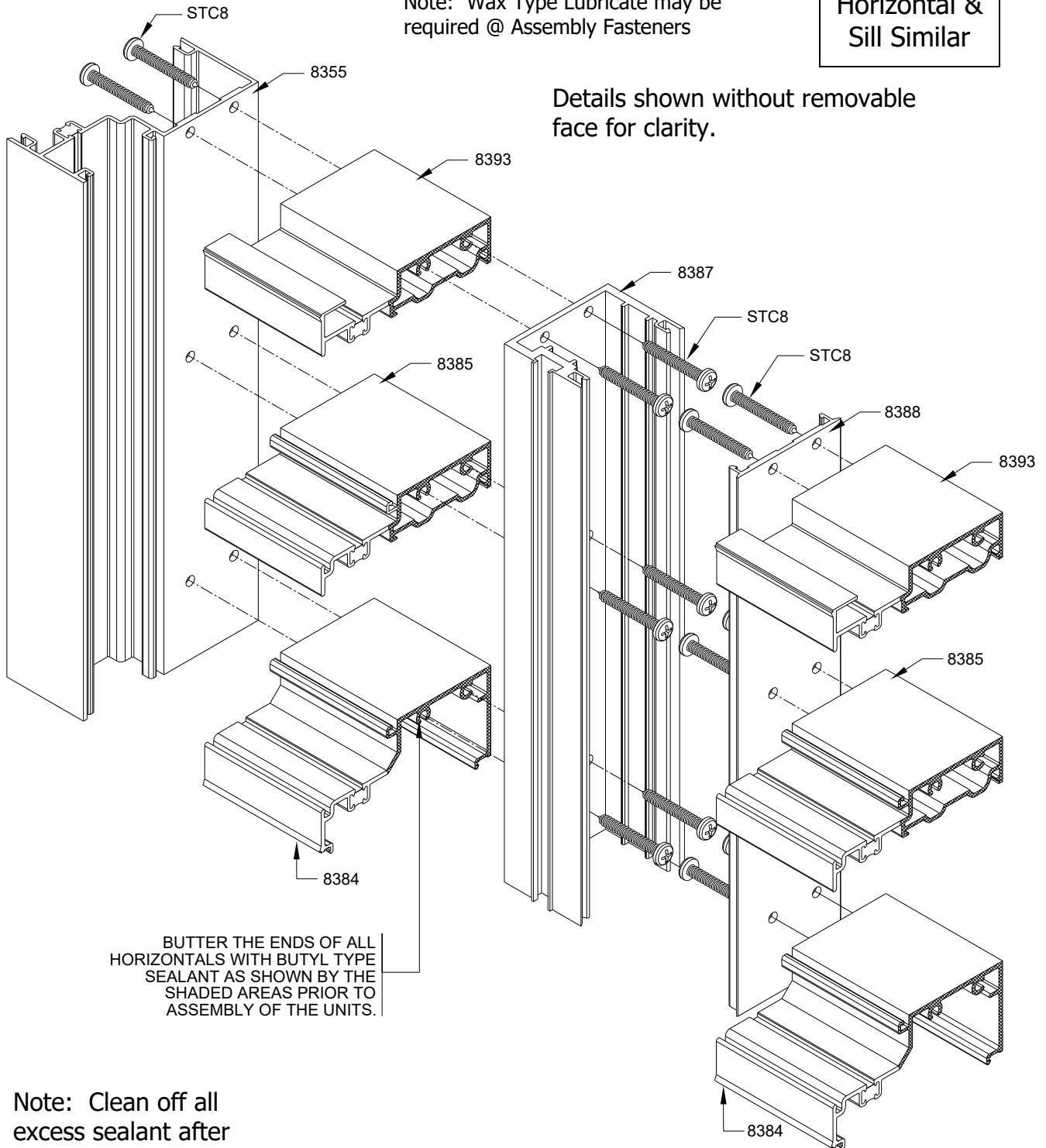

BUTTER THE ENDS OF ALL HORIZONTALS WITH BUTYL TYPE SEALANT AS SHOWN BY THE SHADED AREAS PRIOR TO ASSEMBLY OF THE UNITS.

Note: Clean off all excess sealant after assembly.

## SECTION IV: Unit Assembly

### A. Screw Spline (Offset and Center-Set)

#### Offset Glazed Assembly With Expansion Mullion

Outside Set, Inside Glazed Shown,  
Outside Set, Outside Glazed Similar

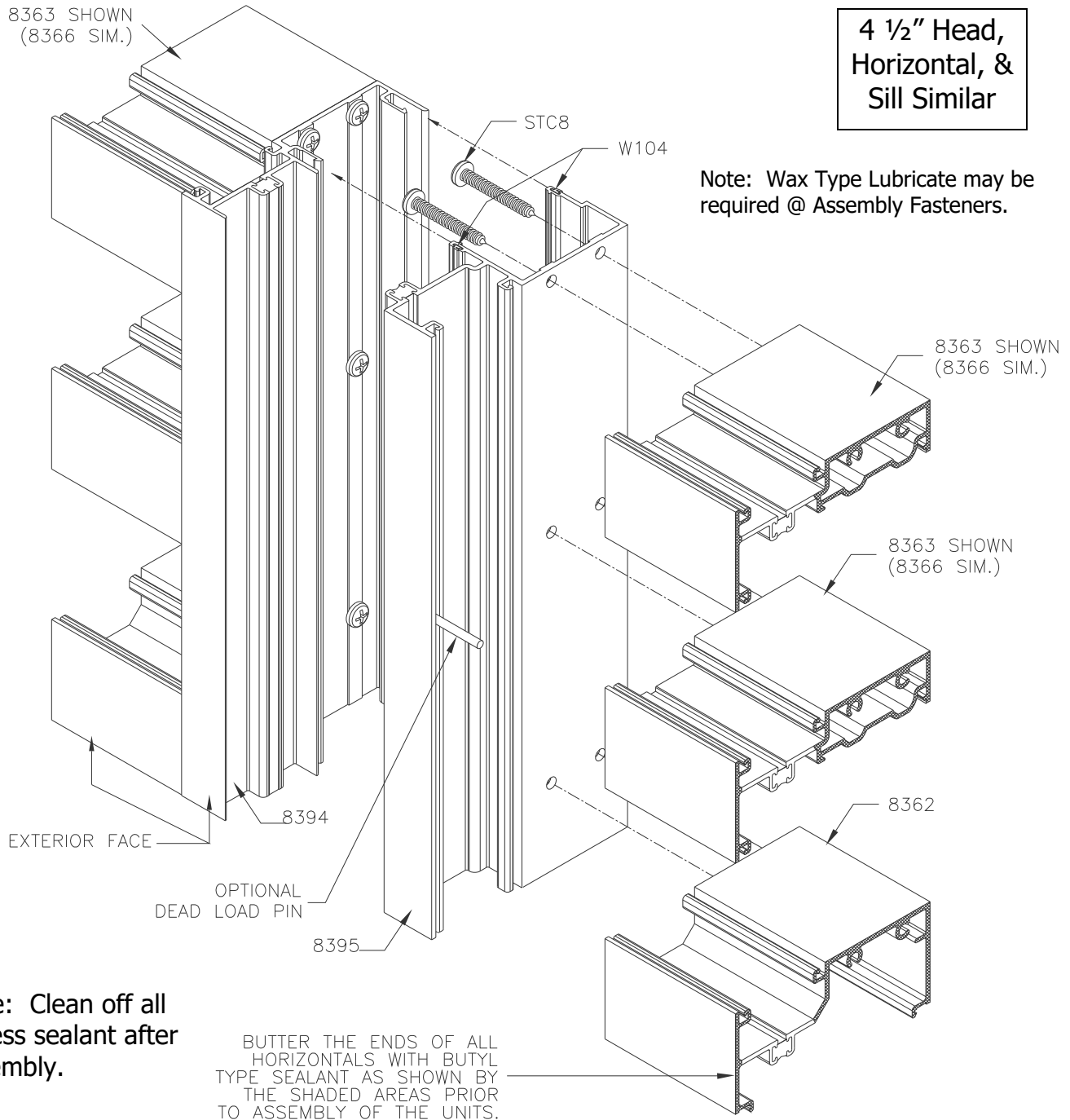

Expansion mullions are required in elevations that are over 20'-25' wide and can be used with both screw spline and shear block systems.

SECTION IV: Unit Assembly

A. Screw Spline (Offset and Center-Set)

Center Glazed Assembly With Expansion Mullion

Inside Glazed

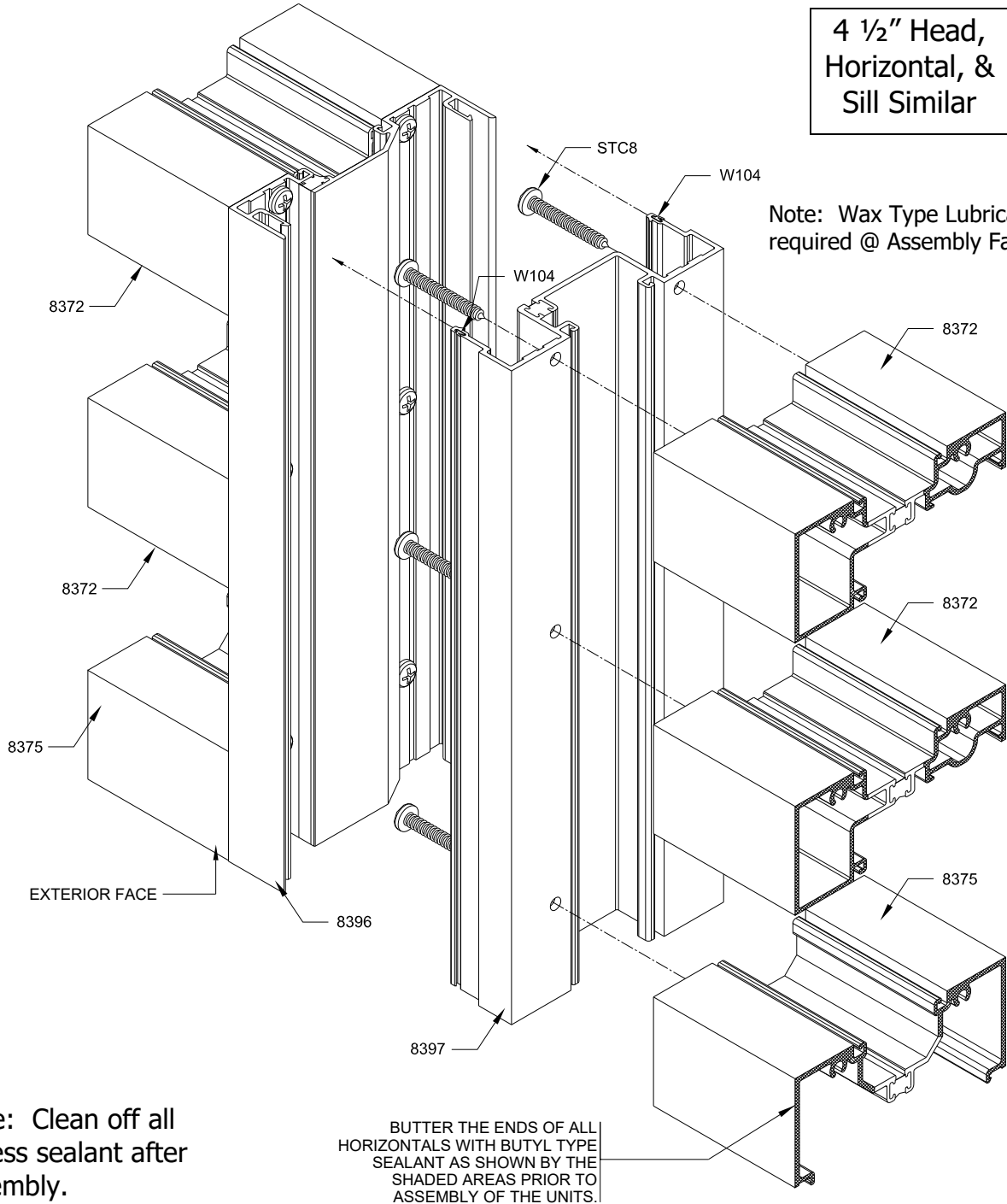

Expansion mullions are required in elevations that are over 20'-25' wide and can be used with both screw spline and shear block systems.

## SECTION IV: Unit Assembly

### A. Screw Spline (Offset and Center-Set)

#### Dead Load Pin Installation

Outside Set Shown  
Inside Set Similar

Use FW95 3" Dead Load Support Pin when there is a Horizontal member on both sides of the Transom Jamb or Vertical.

Use FW96 2" Dead Load Support Pin when there is a Horizontal member on one side of the Vertical or for Door Jambs with side lites.

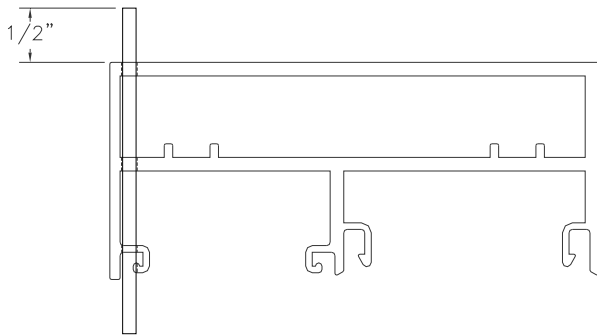
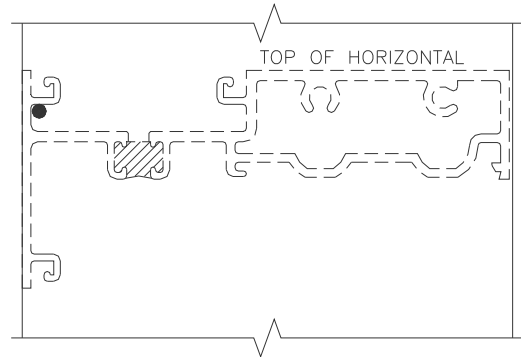
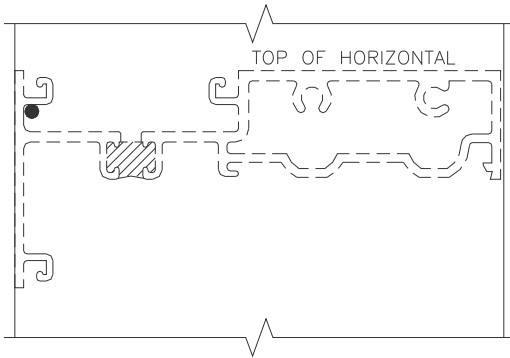

4374

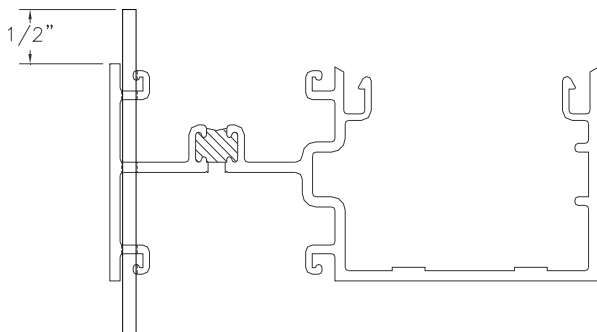
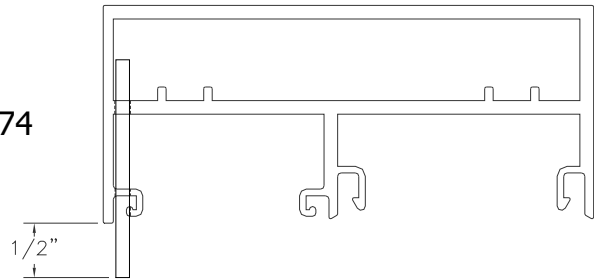

8353

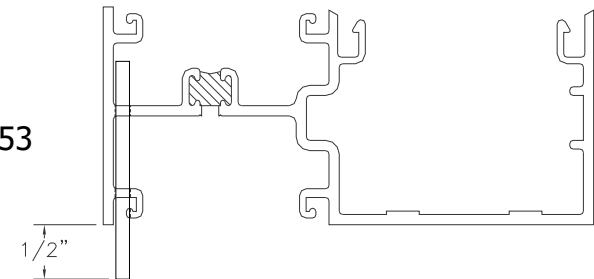

8354 8356  
8355 8374  
DIES SIMILAR TO  
ONE'S SHOWN.

# SECTION IV: Unit Assembly

## B. Shear Block (Offset and Center-Set)

### Offset Glazed Assembly

Inside Set, Inside Glazed shown,  
Other Glazing Variations Similar

4 1/2" Head,  
Horizontal &  
Sill Similar

Shear block packages  
come with all required  
fasteners.

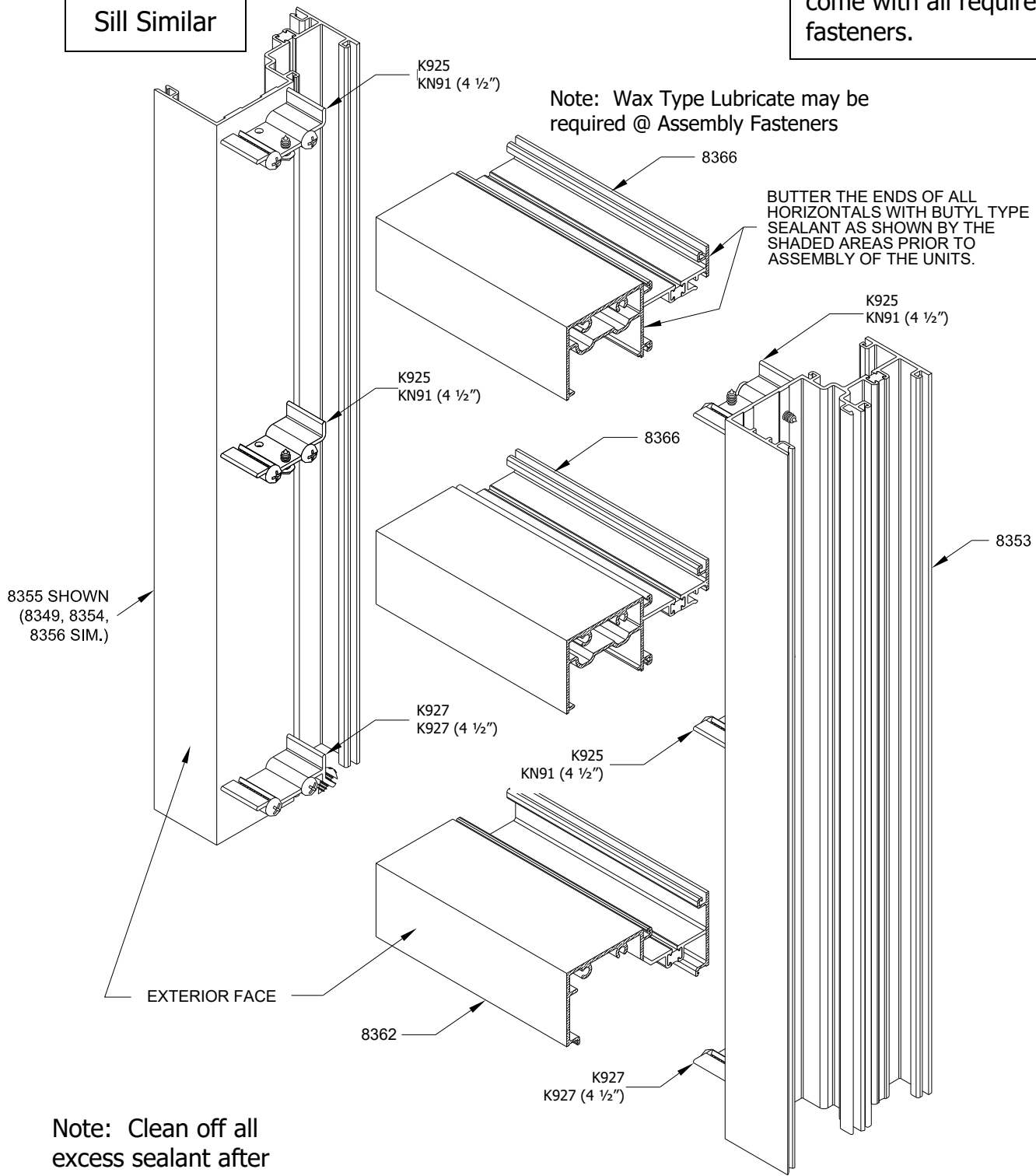

Note: Clean off all  
excess sealant after  
assembly.



# SECTION IV: Unit Assembly

## B. Shear Block (Offset and Center-Set)

### Center-Set Glazed Assembly

4 1/2" Head,  
Horizontal &  
Sill Similar

Inside Glazed shown,  
Outside Glazed similar

Note: Wax Type Lubricate may be  
required @ Assembly Fasteners

Shear block packages  
come with all required  
fasteners.

BUTTER THE ENDS OF ALL  
HORIZONTALS WITH BUTYL  
TYPE SEALANT AS SHOWN  
BY THE SHADED AREAS  
PRIOR TO ASSEMBLY OF  
THE UNITS.

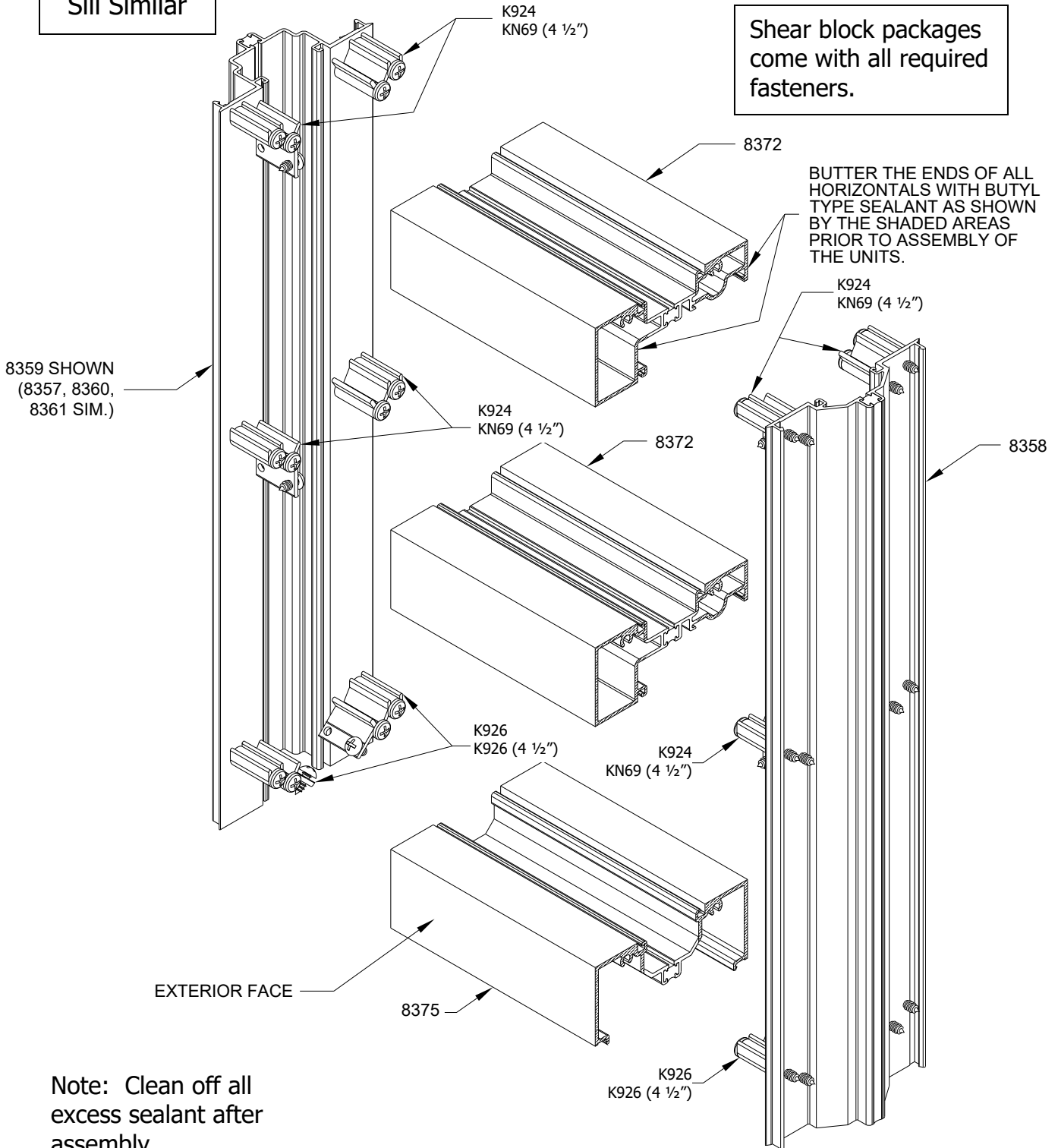

Note: Clean off all  
excess sealant after  
assembly.

## SECTION IV: Unit Assembly

### B. Shear Block (Offset and Center-Set)

#### Dead Load Pin Installation

Outside Set Shown

Inside Set Similar

Use FW95 3" Dead Load Support Pin when there is a Horizontal member on both sides of the Transom Jamb or Vertical.

Use FW96 2" Dead Load Support Pin when there is a Horizontal member on one side of the Vertical or for Door Jambs with side lites.

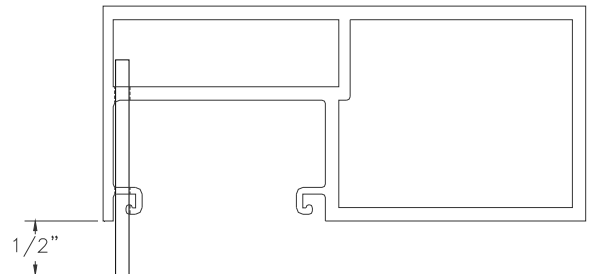
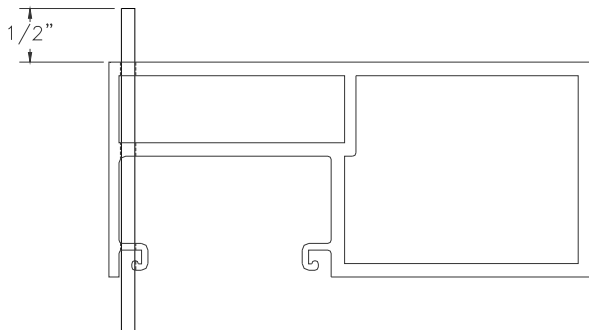
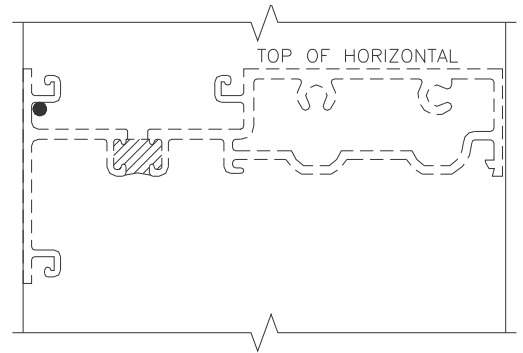
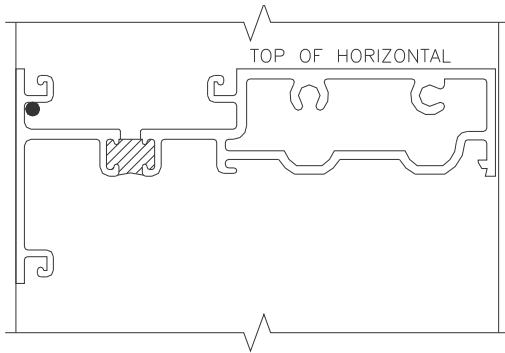

8374

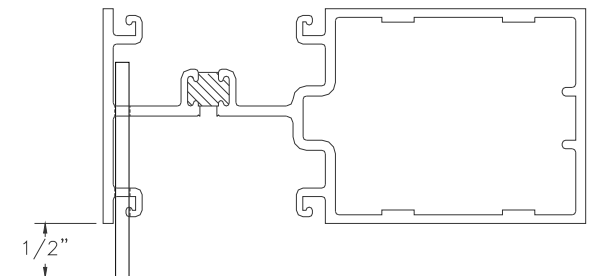
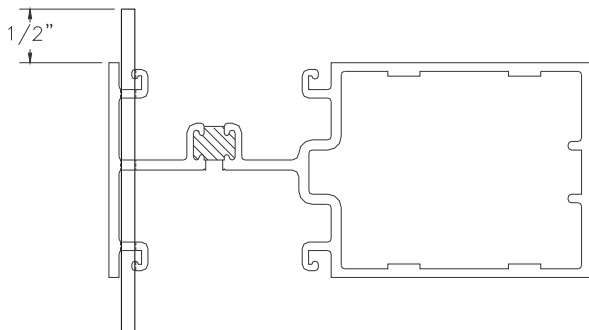

8349

OTHER  
DIES SIMILAR TO  
ONE'S SHOWN.

# SECTION IV: Unit Assembly

## C. Head & Sill Through (Offset)

### Offset Structural Glazed Assembly

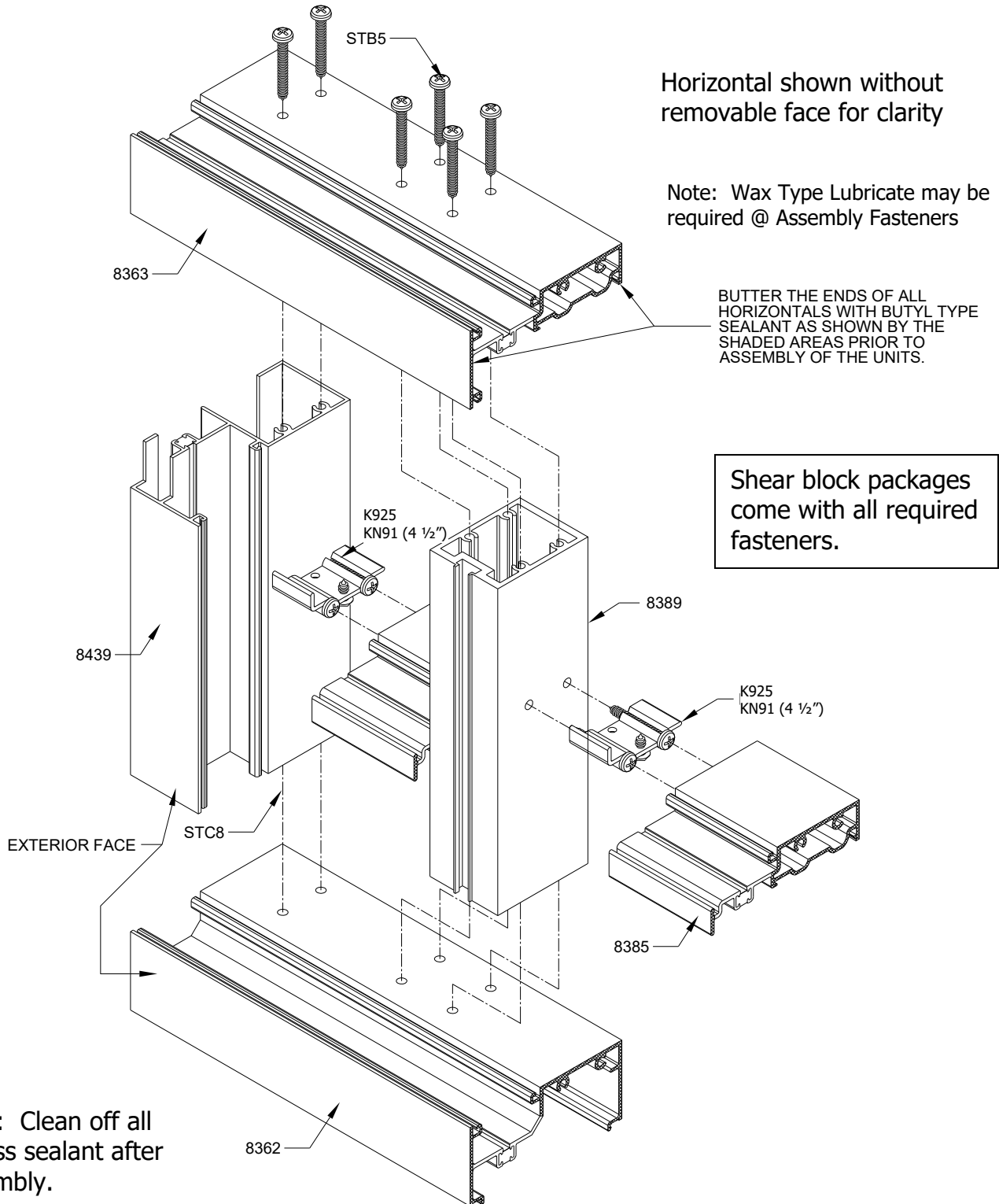

Horizontal shown without removable face for clarity

Note: Wax Type Lubricate may be required @ Assembly Fasteners

BUTTER THE ENDS OF ALL HORIZONTALS WITH BUTYL TYPE SEALANT AS SHOWN BY THE SHADED AREAS PRIOR TO ASSEMBLY OF THE UNITS.

Shear block packages come with all required fasteners.

Note: Clean off all excess sealant after assembly.

## SECTION IV: Unit Assembly

### D. Screw Spline 90° Corner (Offset)

#### Offset Glazed Assembly with 90° Mullion

Corner Mullion can be used at horizontal with removable face only.

See page 31 for sealant notes and locations.

Note: Wax Type Lubricate may be required @ Assembly Fasteners

4 1/2" Head,  
Horizontal &  
Sill Similar

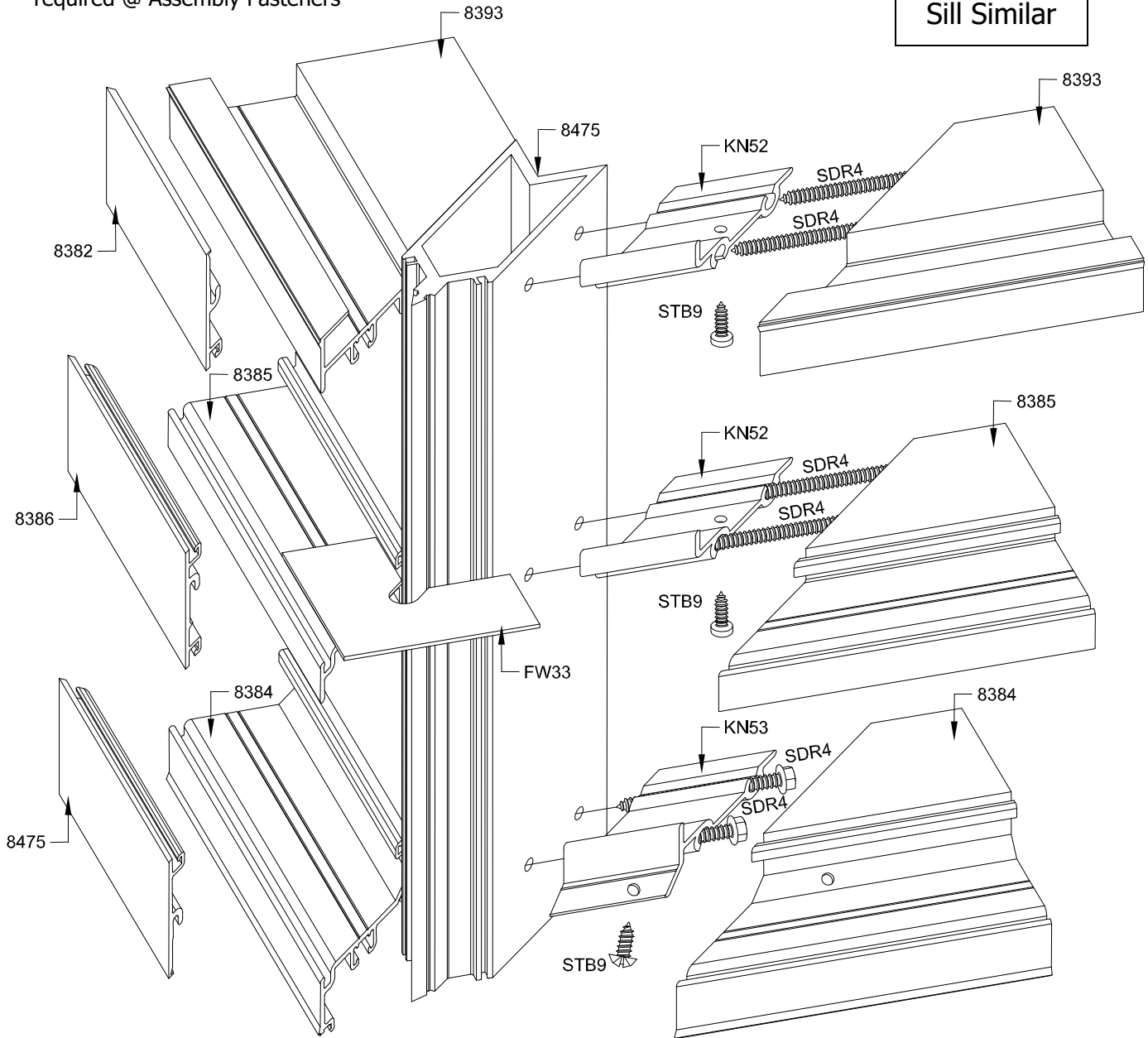

## SECTION IV: Unit Assembly

### E. Rolled Arch Top & Sloped Top (Center Set)

#### Center Glazed Assembly for Slope or Arch Top Inside or Outside Glazed

Note: Wax Type Lubricate  
may be required @  
Assembly Fasteners

BUTTER THE ENDS OF ALL  
HORIZONTALS WITH BUTYL TYPE  
SEALANT AS SHOWN BY THE  
SHADED AREAS PRIOR TO  
ASSEMBLY OF THE UNITS.

Shear block  
packages come  
with all required  
fasteners.

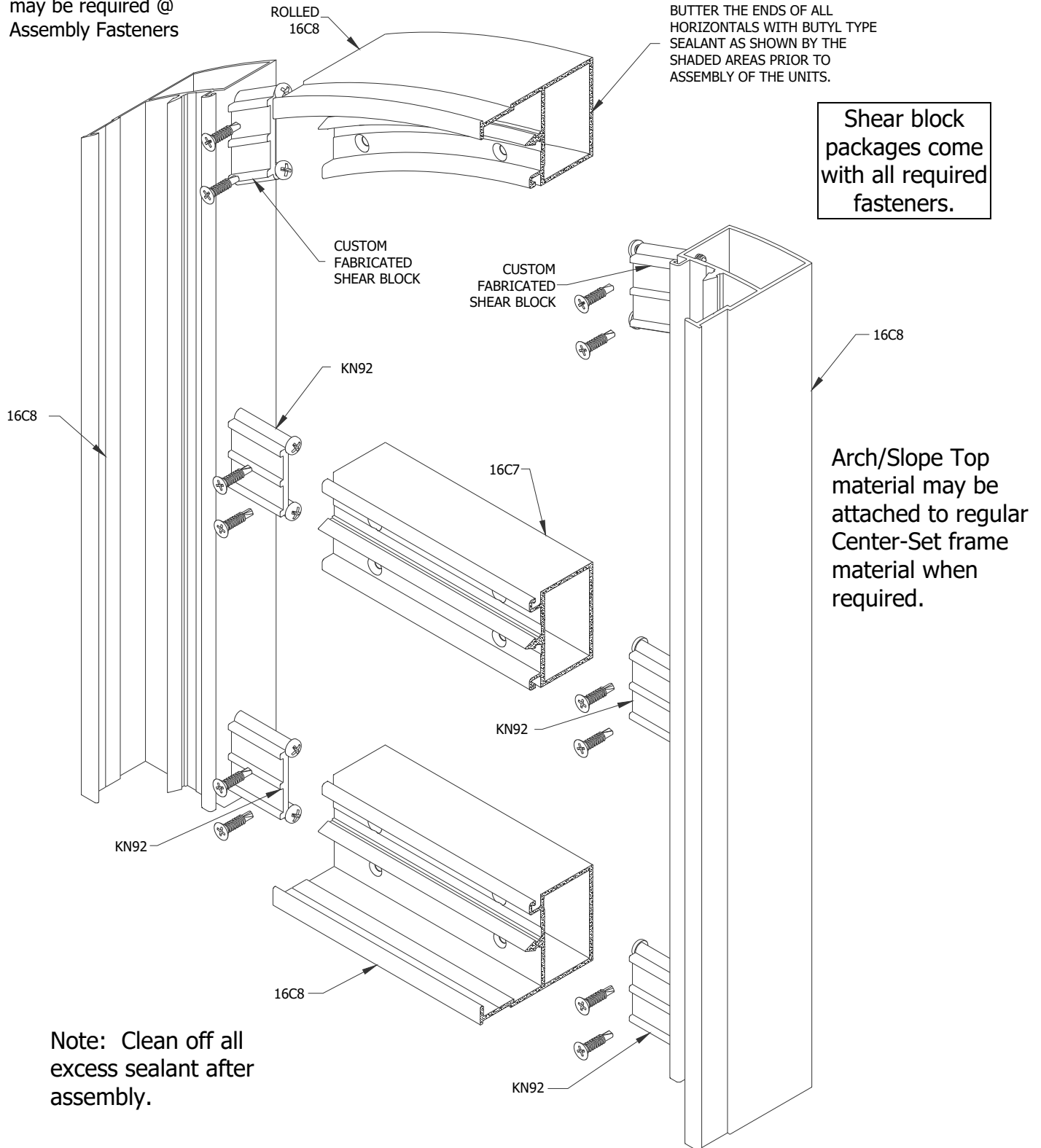

Note: Clean off all  
excess sealant after  
assembly.

## SECTION IV: Unit Assembly

### F. Adjustable Height Side Lite (Offset)

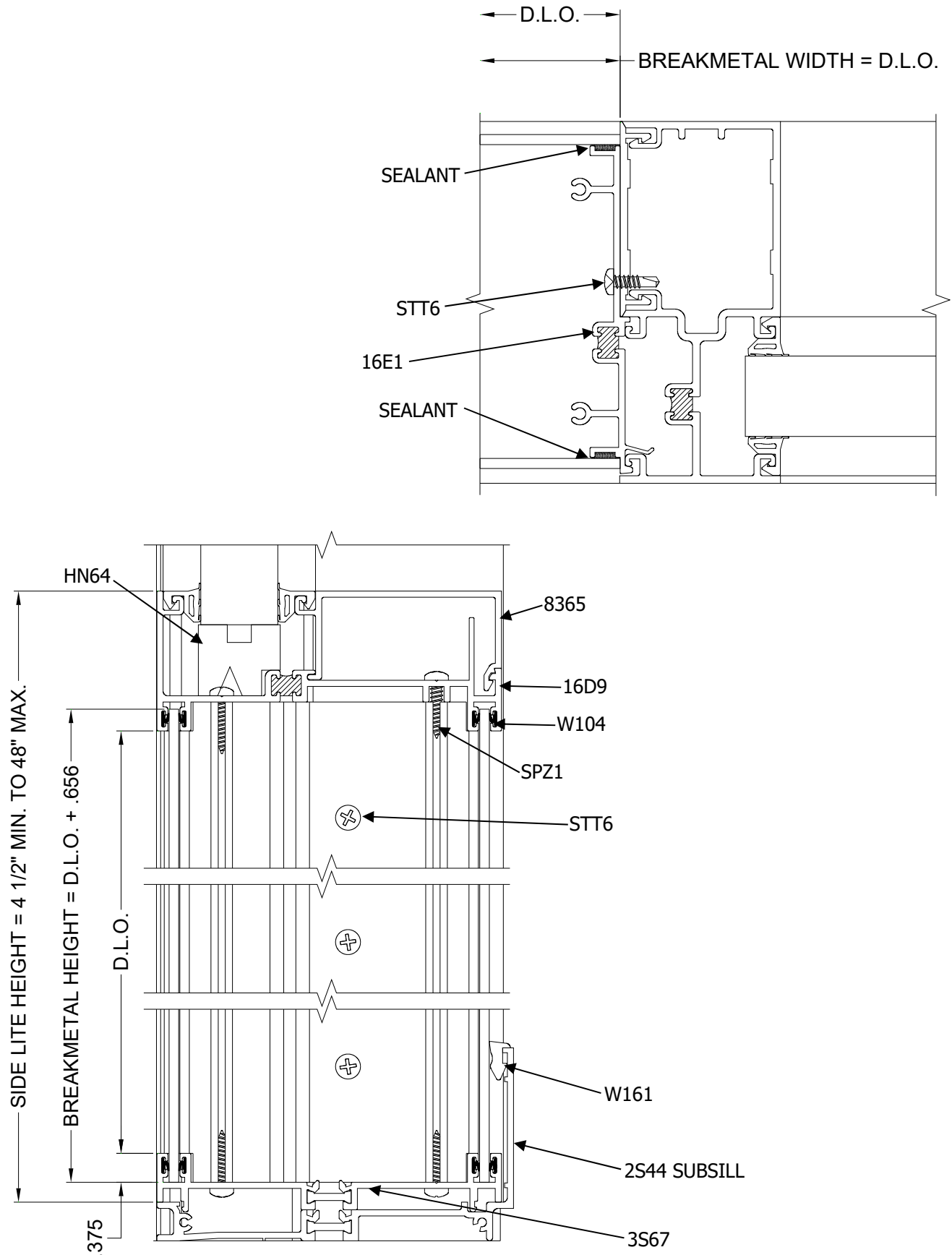

# SECTION IV: Unit Assembly

## F. Adjustable Height Side Lite (Offset) Part Fabrication

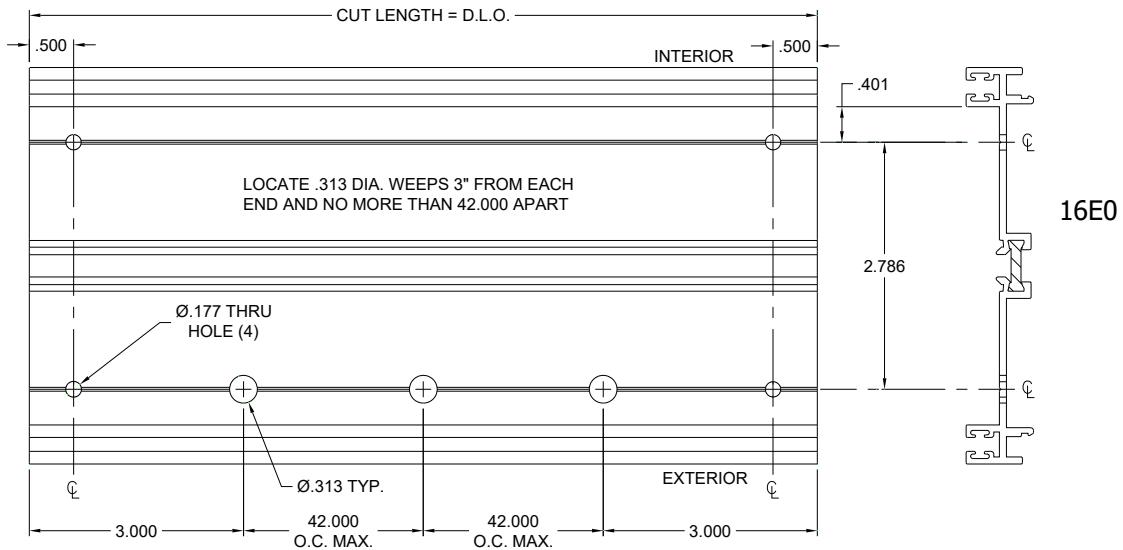
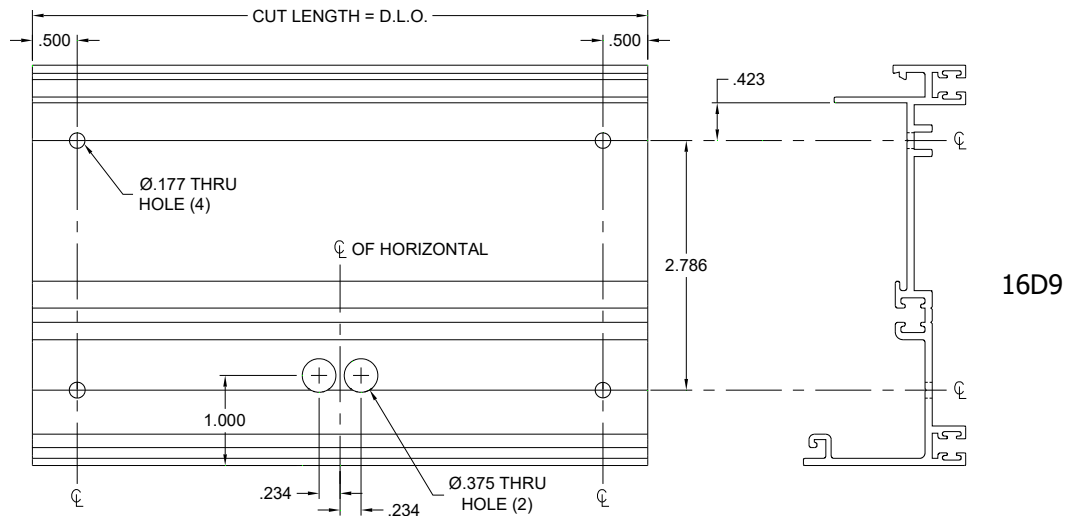
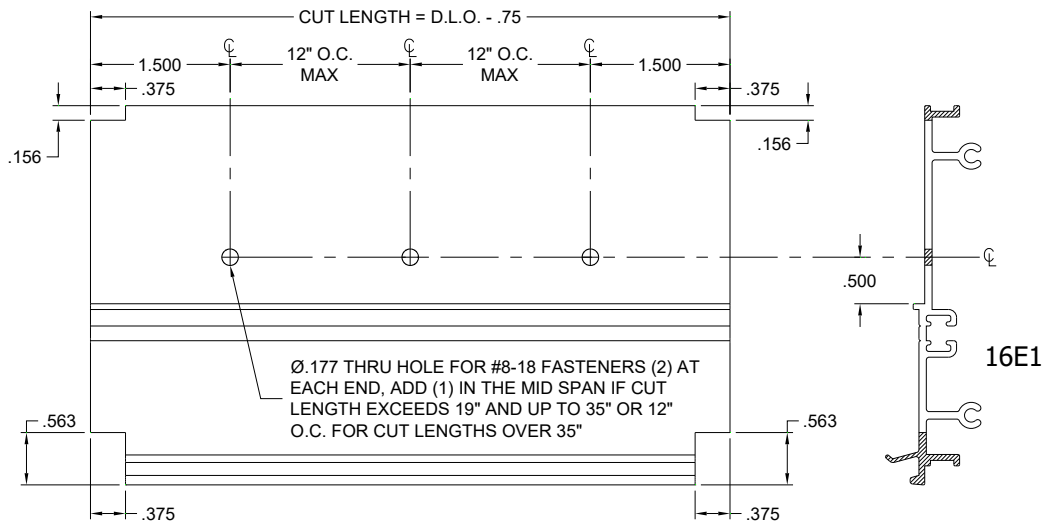

## SECTION IV: Unit Assembly

### F. Adjustable Height Side Lite (Offset) Assembly

ATTACH THE VERTICAL MEMBERS TO THE SILL AS SHOWN. OPTIONAL DEAD LOAD SUPPORT TUBE TO BE USED AS NEEDED.

RUN A CONTINUOUS BEAD OF SEALANT UP THE INTERIOR GASKET RACEWAY FOR THE FULL LENGTH OF THE SIDE LITE VERTICAL.

BUTTER THE ENDS OF ALL HORIZONTALS WITH BUTYL TYPE SEALANT PRIOR TO ASSEMBLY OF THE UNITS.

PLACE ASSEMBLY IN THE FRAME D.L.O. AND ATTACH TO THE JAMBS WITH STT6 FASTENERS.

RUN A CONTINUOUS BEAD OF SEALANT UP THE VERTICAL SEALANT TRACK (INTERIOR & EXTERIOR). SLIDE BREAK METAL INTO PLACE AND ATTACH HORIZONTAL AS SHOWN BELOW.

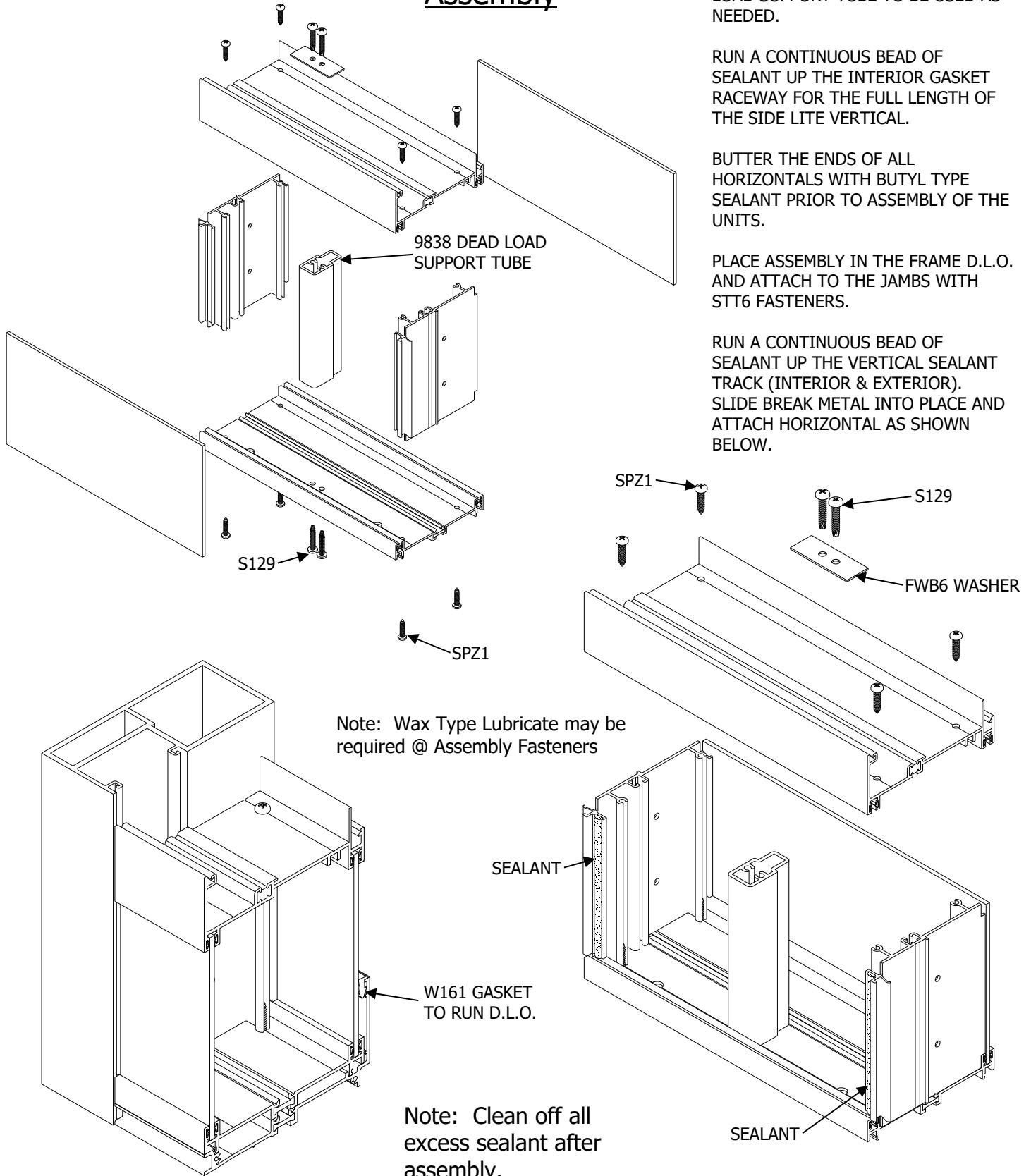

Note: Wax Type Lubricate may be required @ Assembly Fasteners

Note: Clean off all excess sealant after assembly.



## SECTION V: Door Frame Installation

### Step 1) General Notes

If a door opening is required, the doorframe must be installed first. The subsill must be installed into the opening from the door framing, ensuring that the appropriate clearance is available for the doorframe. All subsequent ladders must be installed from the doorjamb out.

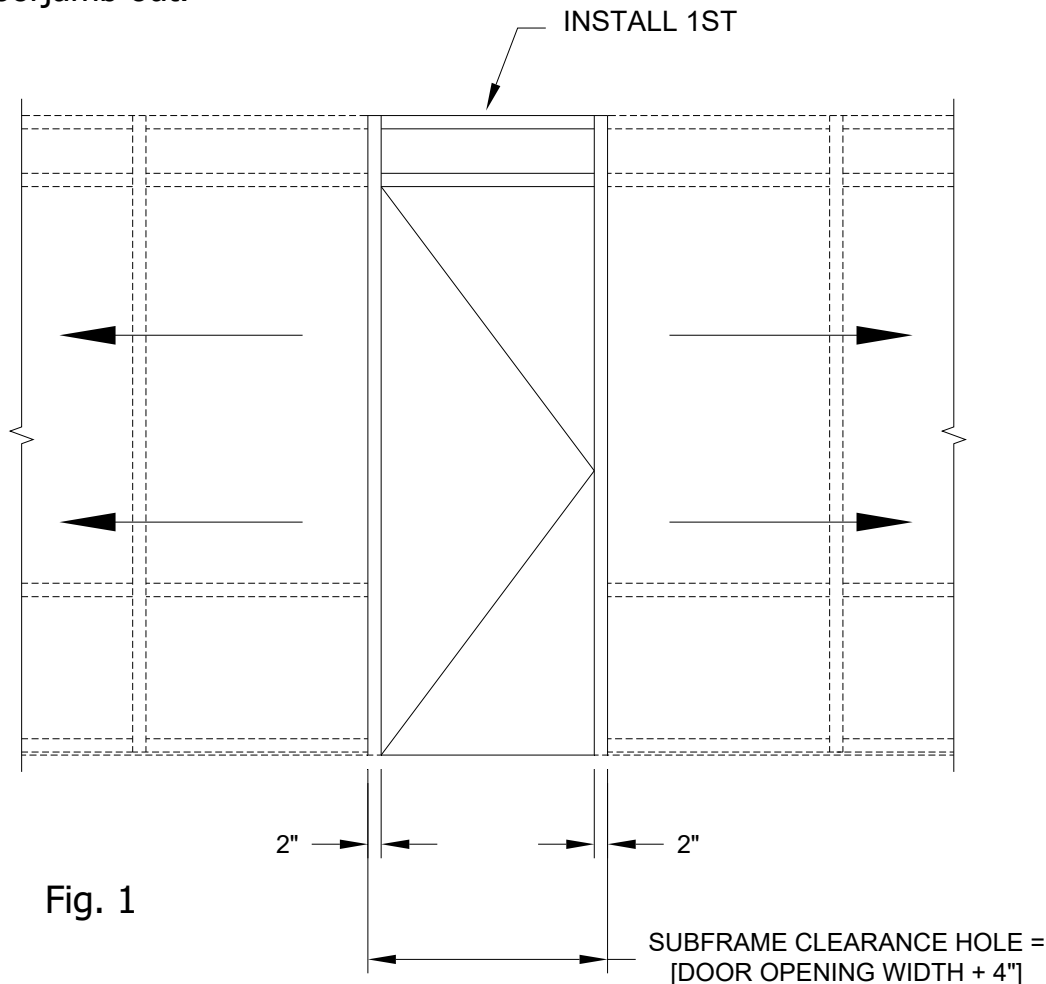

Fig. 1

Note: Door jambs do not set on the subsill. Door jambs must run through to the floor condition.

### Step 2) Subsill Installation at Door Opening

Where a door opening is required, use the equation in Figure 1. Install the door frame true and plumb in the opening as specified on the shop drawings or architectural drawings. Install the subsill in the same manner as illustrated on pages 46 through 54. End dams are not required at the door frame end of the subsill. The subsill should butt up tight tot the door frame. See Figures on page 46 for subsill sealant requirements at the door framing.

## SECTION V: Door Frame Installation

### Step 3) Subsill Installation at Door Opening

Before installing the subsill to the door frame, seal the end of the subsill with a silicone type sealant. Install the subsill and tool all excess sealant into the joint where the subsill and door jamb meet. If required, add more sealant to create a smooth watertight seal. At the glazing pockets, a build-up of silicone sealant must be used to fill the depth of the pocket up to the level of the subsill at the glazing area. See below for sealant application at the subsill to door jamb joint.

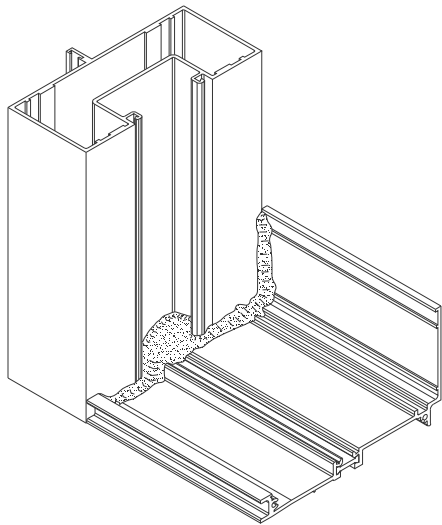

[Fig. 2]

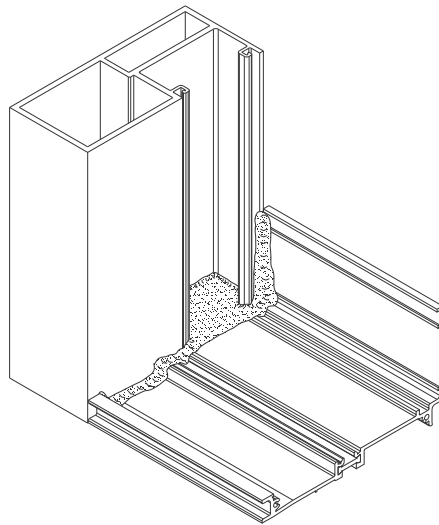

[Fig. 3]

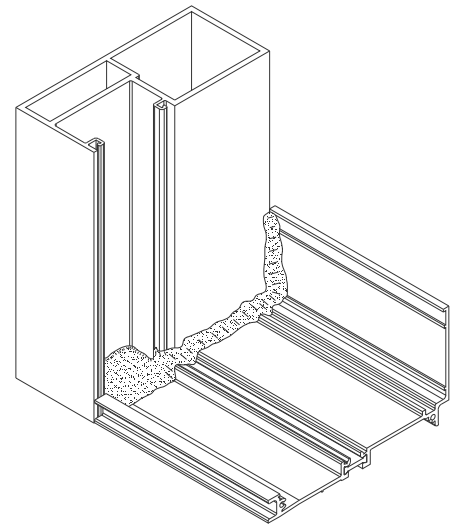

[Fig. 4]

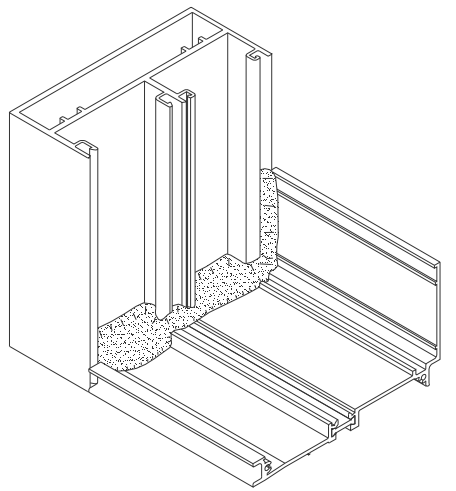
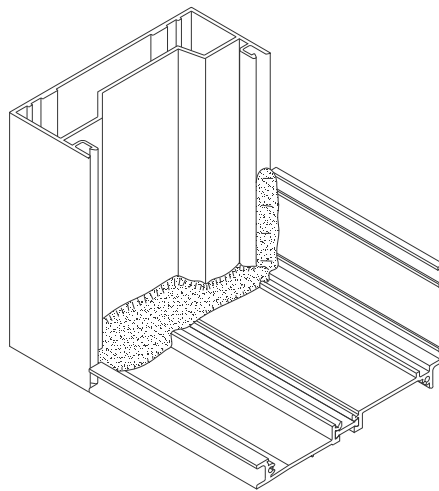
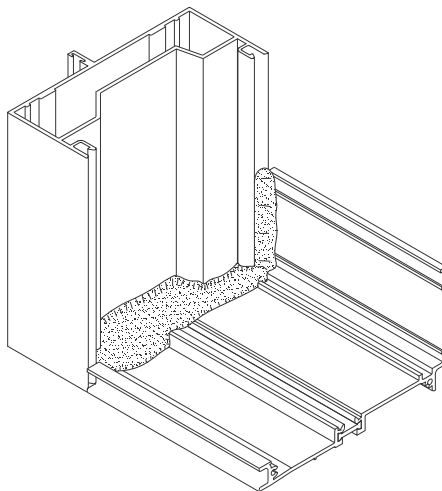

**NOTE:** Fill the glazing pocket of the door jamb flush with the silicone sealant to the tallest portion of the subsill that bridges the glazing pocket. Tool the silicone sealant so a watertight seal is made, so that water will be directed out of the glazing pocket and into the subsill.

Pocket of the door jamb flush with the silicone sealant to the tallest portion of the subsill that bridges the glazing pocket. Tool the silicone sealant so a watertight seal is made, so that water will be directed out of the glazing pocket and into the subsill.

## SECTION VI: Subsill Fabrication and Installation

(Includes Offset and Center-Set Glazing)

### Step 1) Cut Length

Measure the opening to determine the cut length of the subsill. Subtract ¼" for the width of the end dam and fastener head from the rough opening for each end. Cut the subsill to the determined length.

If end dams are not required, cut the subsill to the rough opening width.

CUT LENGTH = R.O. - 1/2" <sup>+1/8"</sup><sub>-0"</sub> for end dams (See Figure 5)  
 CUT LENGTH = R.O. for no end dams (See Figure 5)

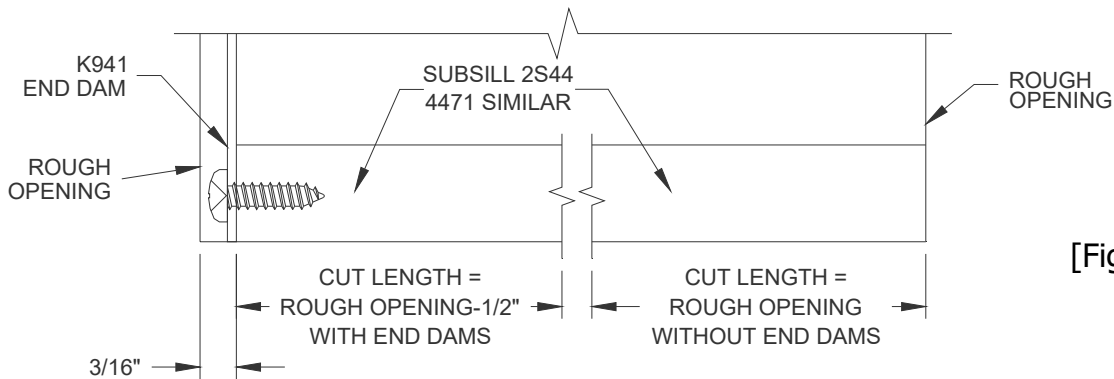

[Fig. 5]

### Step 2) End Dam Installation

The end dam shall be attached to the subsill with 2 SPP2 fasteners on each end. Seal the end of the subsill with silicone sealant before attaching the end dam to the subsill. Tool the sealant at the interior joint of the end dam to ensure a good watertight seal. See Figure 6 below. If end dams are not required, ensure the subsill is tight against the condition and seal the joint between the subsill and condition similar to Figure 6.

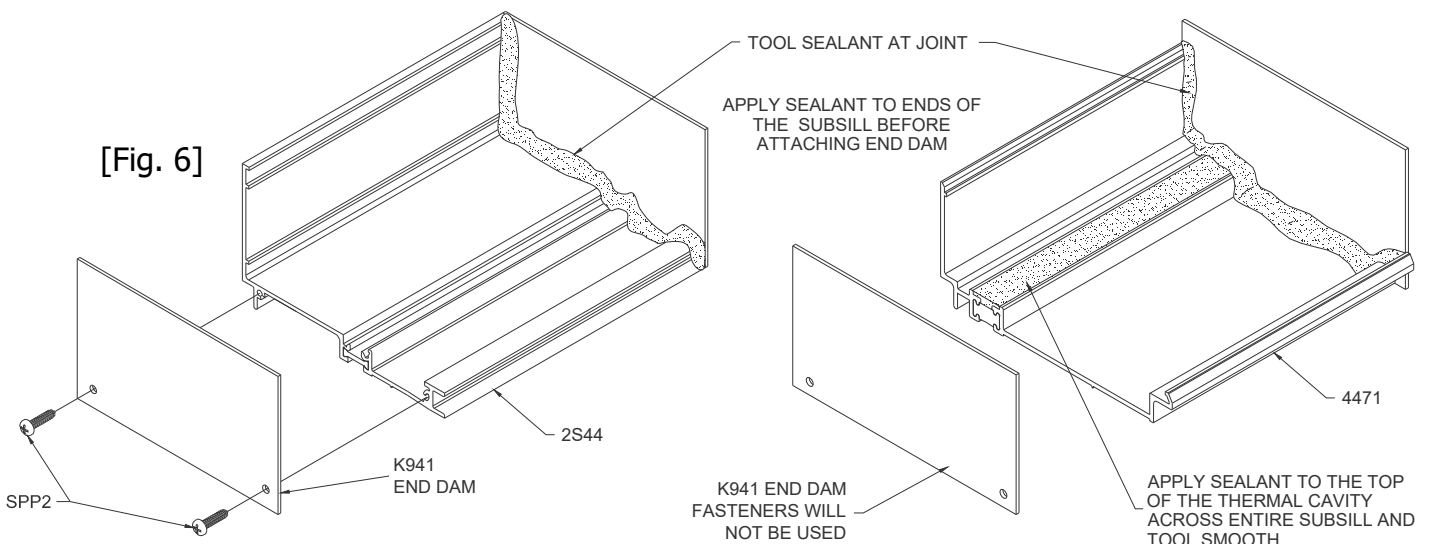

## SECTION VI: Subsill Fabrication and Installation

(Includes Offset and Center-Set Glazing)

### Step 3) Weep Fabrication

Drill 5/16" weep holes in the subsill 6" from jambs and no more than 42" apart.

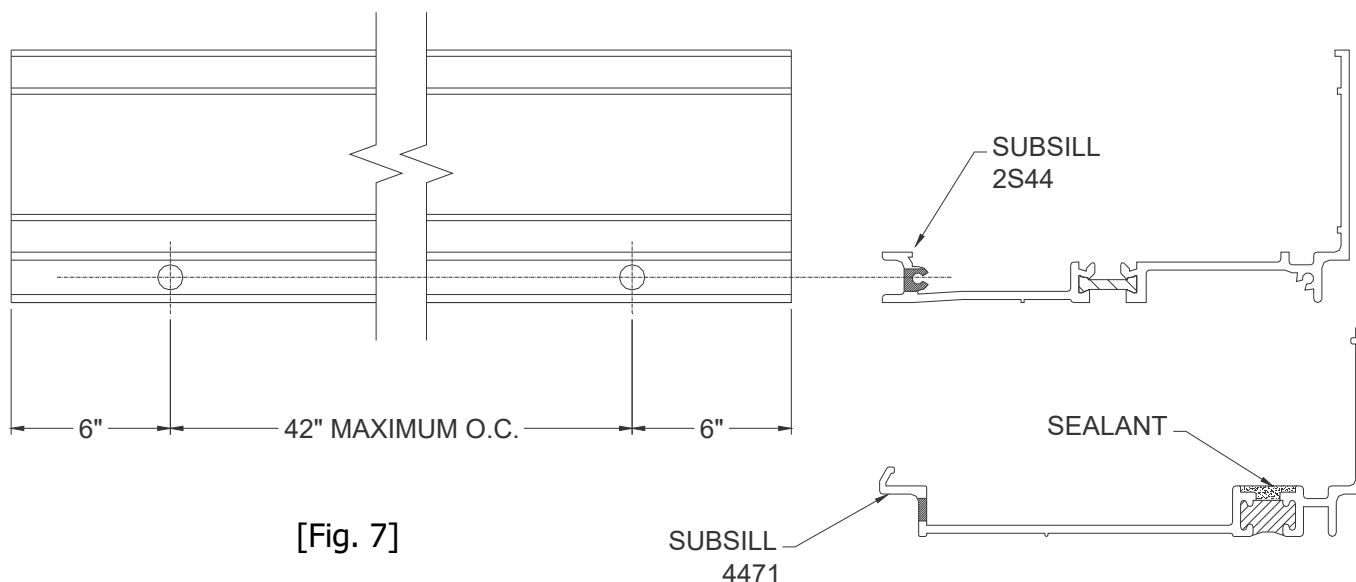

[Fig. 7]

### Step 4) Weep Baffle Installation

Weep baffles are cut from (1) HCW6, halved. This provides (2) weep baffles per HCW6. See Fig. 8 below.

Apply a small amount of silicone type sealant to the baffles, and locate them over the weep holes as shown in Figure 8 below.

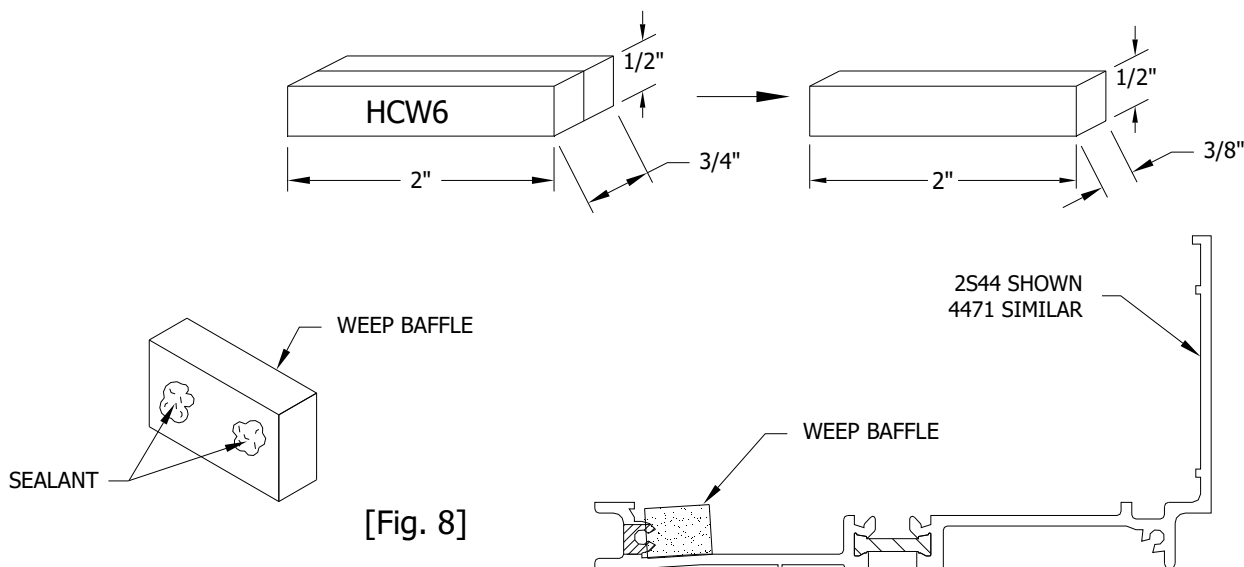

[Fig. 8]

## SECTION VI: Subsill Fabrication and Installation

(Includes Offset and Center-Set Glazing)

### Step 5) Chalk Line for Subsill

Before installing the subsill, measure the distance from the exterior of the condition to the desired location at the EXTERIOR of the subsill. (The exterior of the subsill will be flush with the rest of the system.) Do this at both ends of the condition. Snap a chalk line between the two marks to align the subsill. If the condition is too wide for just two marks, measure every 15 feet and snap a chalk line.

### Step 6) Sealant Bed

Apply sealant to the subsill as shown in Figures 9 and 10. Place the subsill into the rough opening, and rotate the exterior face down into position. Apply enough sealant to ensure a complete seal as shown in Figure 11.

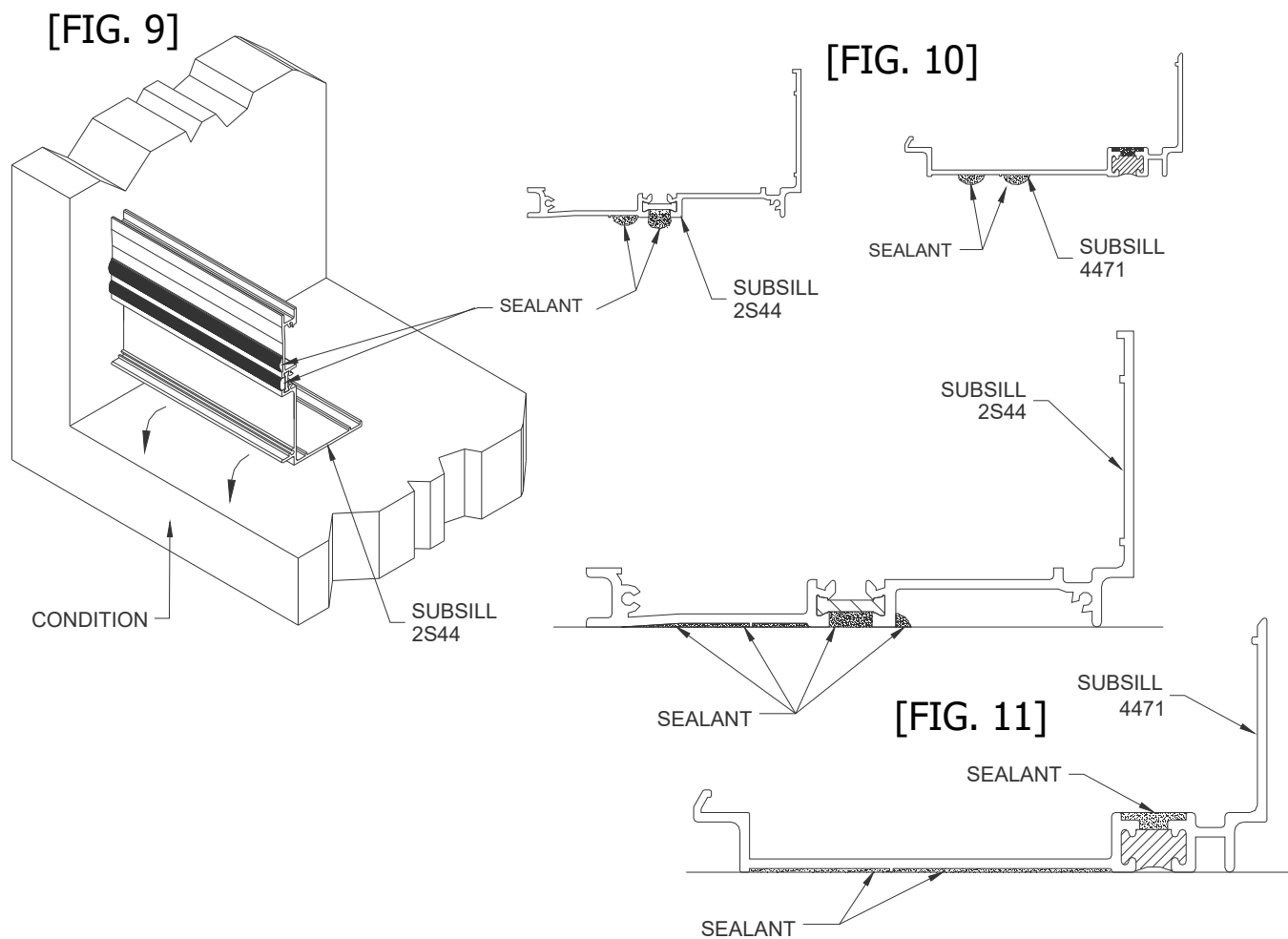

## SECTION VI: Subsill Fabrication and Installation

(Includes Offset and Center-Set Glazing)

### Step 7) Subsill Anchor Installation

At a minimum, anchor at 6" from jambs and corners and 16" O.C. Staggering locations from one side of thermal area to the other for 2S44 only.

These recommendations are for general erection procedures only. For actual job conditions, see the details on the shop drawings. For perimeter anchor type and spacing, refer to the approved shop drawings or consult the project design professional.

(ANCHORING FASTENERS NOT SUPPLIED BY EFCO)

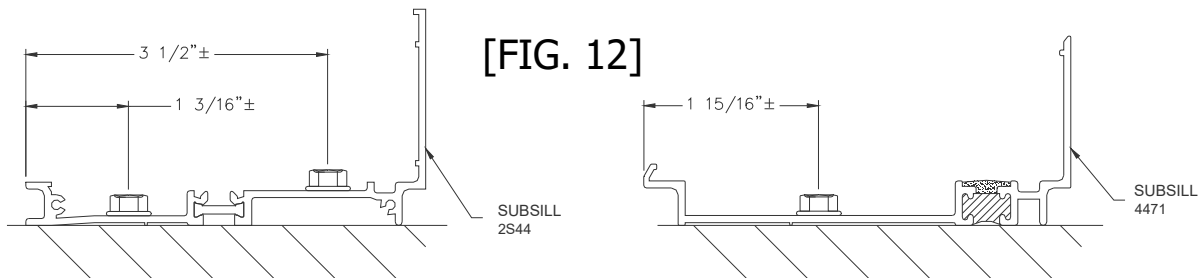

For standard applications, utilize anchorage shown in Figure 12. If heavy-duty anchorage is required, install standard anchors as shown, and refer to the location of heavy-duty anchors as shown in Figures 14 through 18 on page 51.

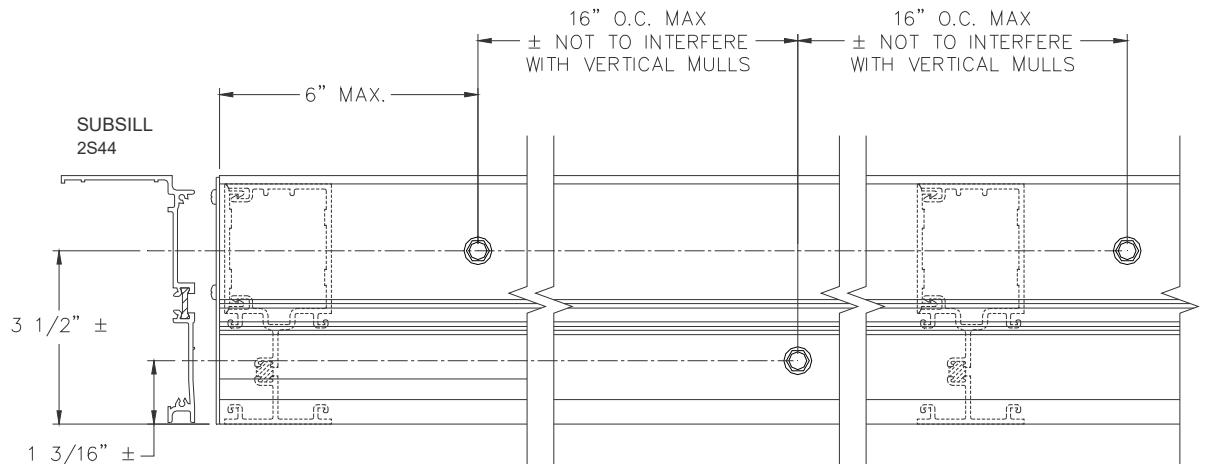

[FIG. 13]

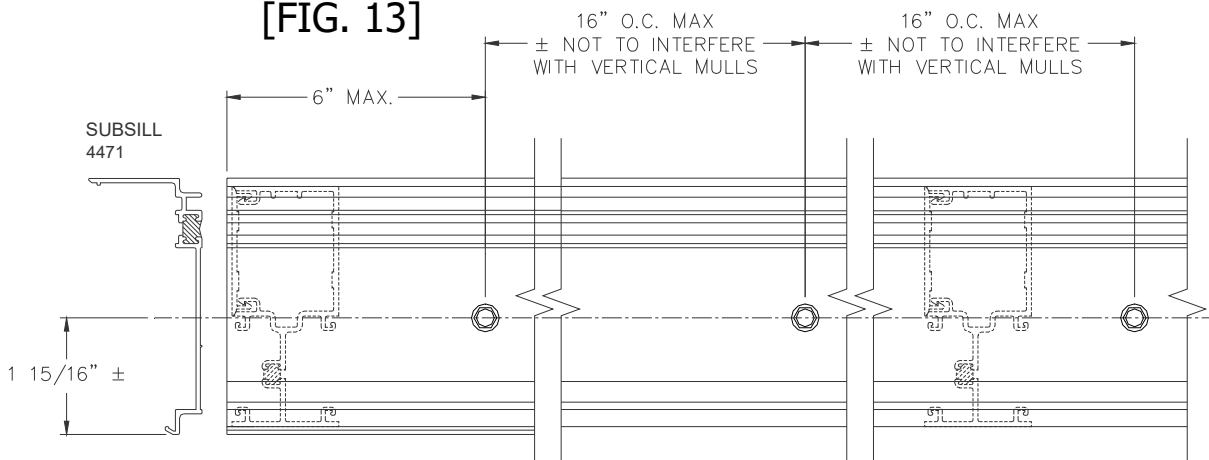

# SECTION VI: Subsill Fabrication and Installation

(Includes Offset and Center-Set Glazing)

Do not use 4471 Subsill with heavy duty anchors.

## Step 8) Heavy-Duty Anchor Installation

### OUTSIDE SET GLASS

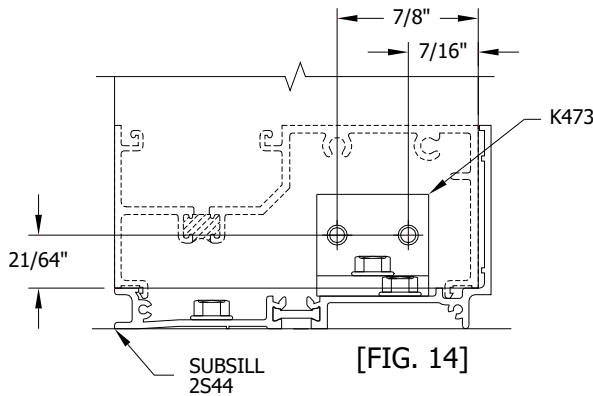

Install required vertical mullion anchors as shown in Figures 14 through 18. Anchors should be installed on the vertical mullions and anchored thru the subsill after the frame unit is installed in the opening. HD anchors will not work with 8349 or 8357 mullions.

### INSIDE SET GLASS

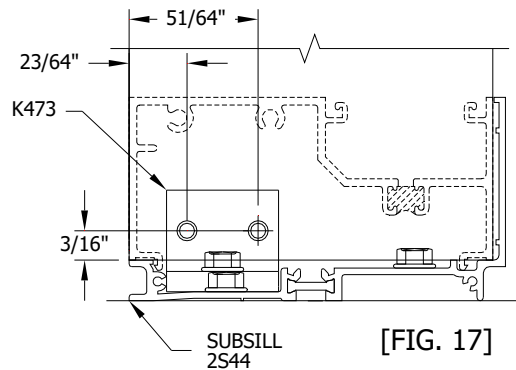

NOTE: K992 COMES WITH TWO ANGLE BRACKETS AND TWO FASTENERS. K473 COMES WITH ONE ANGLE BRACKET AND TWO FASTENERS.

### CENTER-SET GLASS

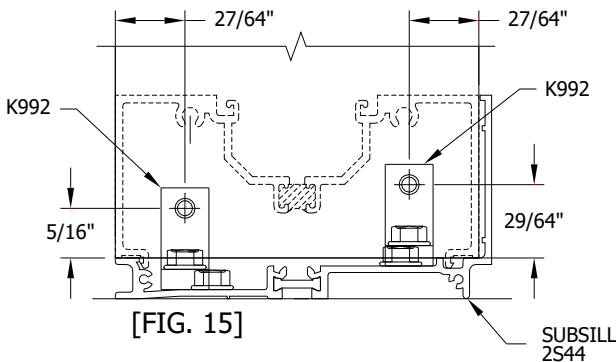

### OFFSET MULLIONS

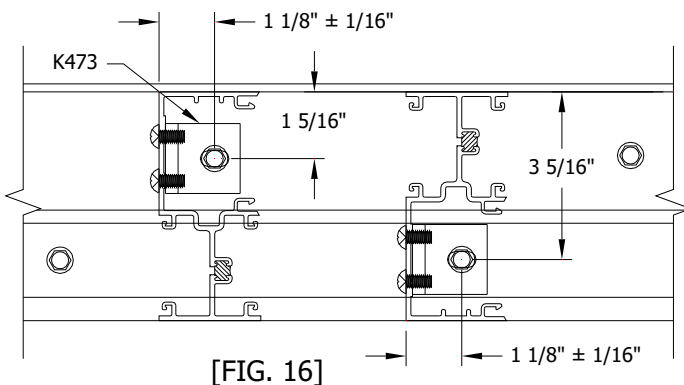

### CENTER-SET MULLIONS

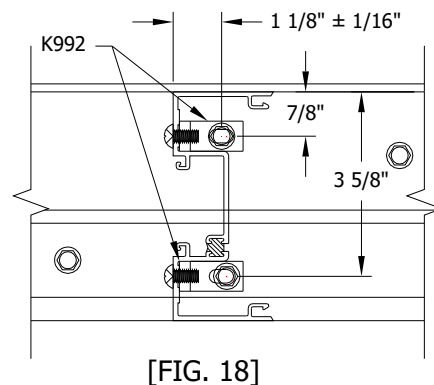

These recommendations are for general erection procedures only. For actual job conditions, see the details on the shop drawings. For perimeter anchor type and spacing, refer to the approved shop drawings or consult the project design professional.

## **SECTION VI: Subsill Fabrication and Installation**

(Includes Offset and Center-Set Glazing)

### **Step 9) Subsill Anchor Seal**

The subsill anchors must be sealed with a silicone type sealant. To ensure a good seal, tool the sealant onto the fastener and surrounding metal. If HD anchors are used, ensure that the anchor angle and fasteners are sealed also. This procedure should be followed immediately after anchor installation so it is not forgotten.

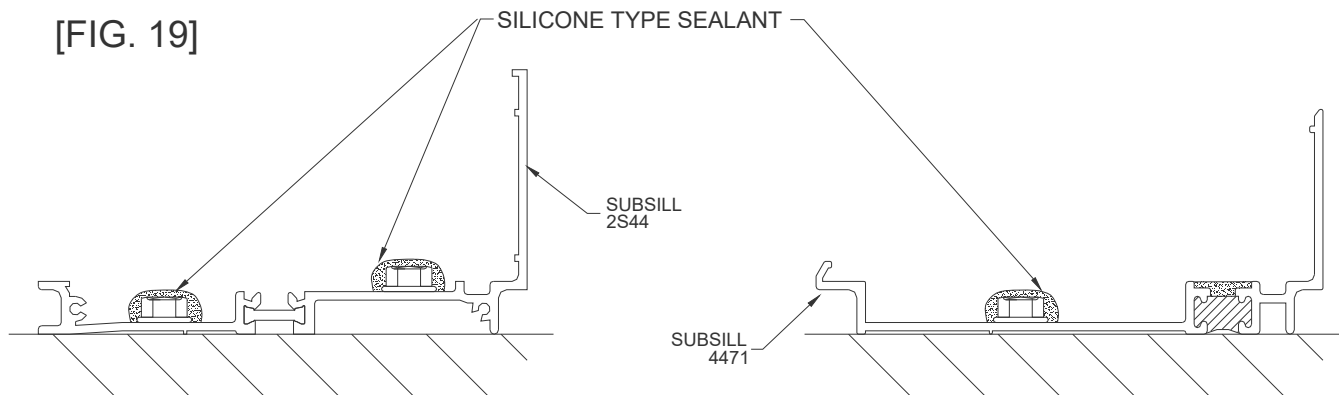

### **Step 10) Subsill Perimeter Seal**

The subsill interior should be sealed with a silicone type sealant. Apply sealant and tool the sealant to ensure a good seal. Clean off all excess sealant. At this time, use a silicone type sealant to seal the thermal break area as shown in Figure 20. Tool the sealants into the thermal break area, and ensure that sealant is smooth and flat with the subsill surface. This procedure should be done prior to installation of the framing system so it is not forgotten.

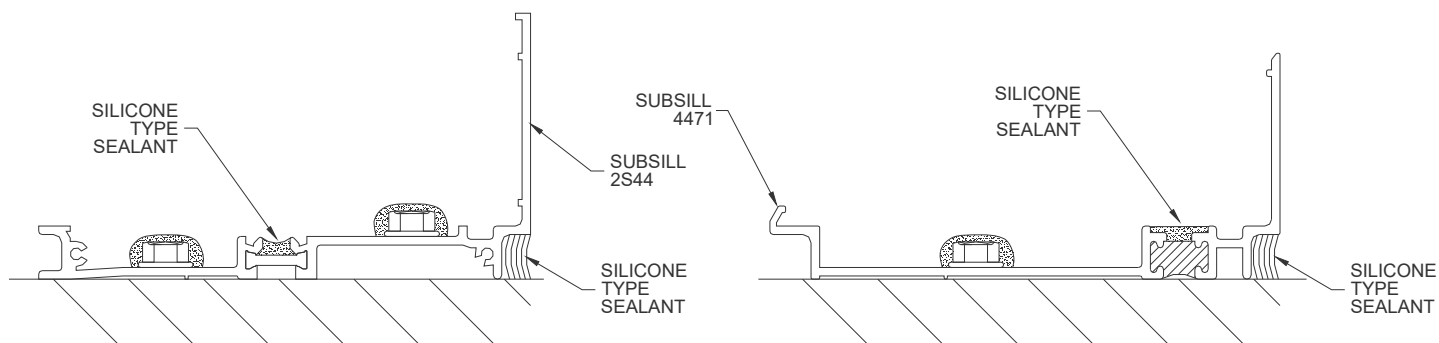

[FIG. 20]



## **SECTION VI: Subsill Fabrication and Installation**

(Includes Offset and Center-Set Glazing)

### **Step 11) Subsill Splicing**

Verify that the subsill has been installed according to the instructions on pages 45 through 52. Splice areas are to be centered at a vertical mullion only. Maximum subsill length between splices is 20' to 25'. If a splice is required, leave a 1/4" gap between the subsill ends at the splice area. Install and anchor the next run of subsill. Use a silicone type sealant and a strip of WM01, bond breaker tape 1 7/8", wide and approximately 7 1/2" long to create the splice material. Apply silicone to both sides of the subsill ends and fill the void between the subsills as shown in Figure 21. Ensure that the bond breaker tape is centered over the 1/4" gap, and set the bond breaker tape into the sealant. Tool the silicone over the bond breaker tape to create a watertight seal. If more sealant is required to cover the bond breaker tape, apply the required amount. Ensure that the splice joint does not interfere with the anchor legs of the sill and subsill. Making sure that the splice joint is located at the center of the vertical mullions does this. Refer to the shop drawings or architectural drawings for mullion centerlines.

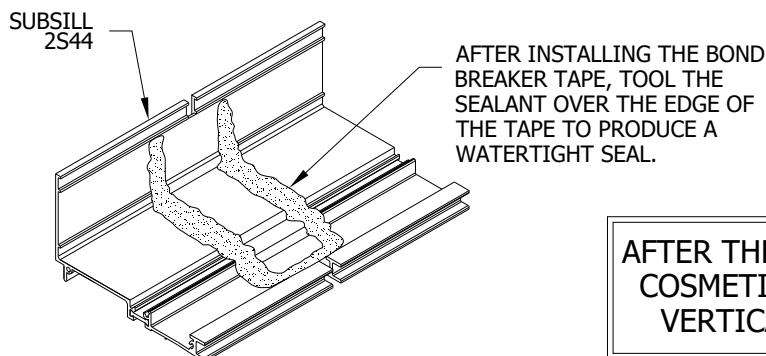
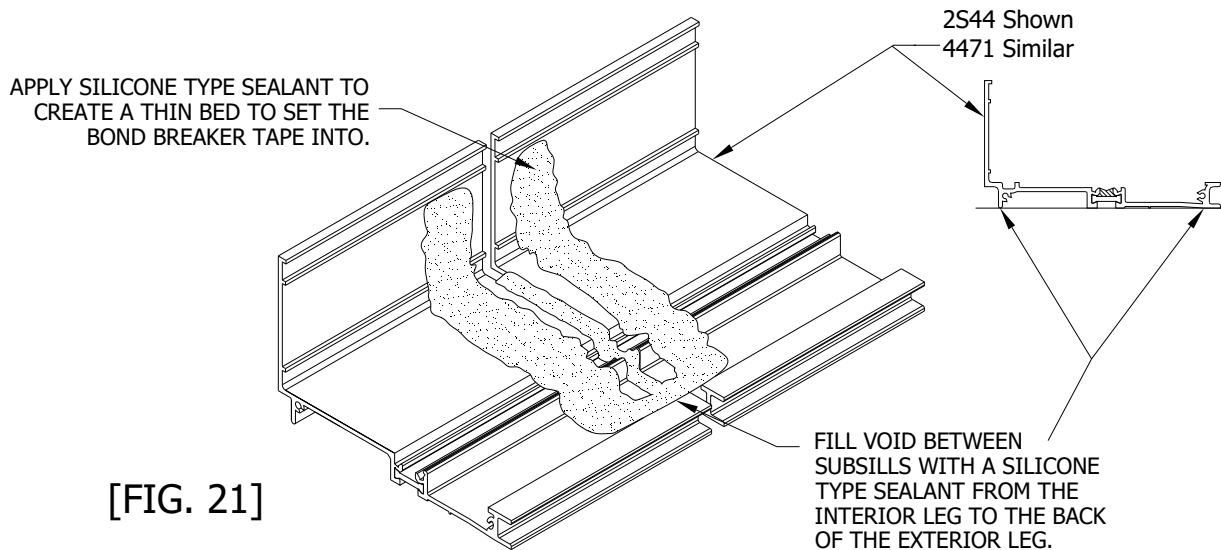

## **SECTION VI: Subsill Fabrication and Installation**

(Includes Offset and Center-Set Glazing)

### **Step 12) Subsill Corner Miter and Splicing**

When mitering the subsill for corner applications, cut the subsill material at the appropriate angle required to form the correct corner. Install the subsill by following the previous subsill installation instructions. Once the subsill is installed and a tight miter joint is achieved, use the instructions on page 53 for creating a splice joint seal. Follow the instructions for sealing a standard splice joint except there should be no gap between the ends of the mitered subsills. Ensure that the bond breaker tape and sealant used to create the seal are smooth, so they do not interfere with the anchor legs on the sill and subsill. If a 90° SSG mullion is used, the bond breaker tape should be 1-1/2" wide because the corner mullion is 1-3/4" wide.

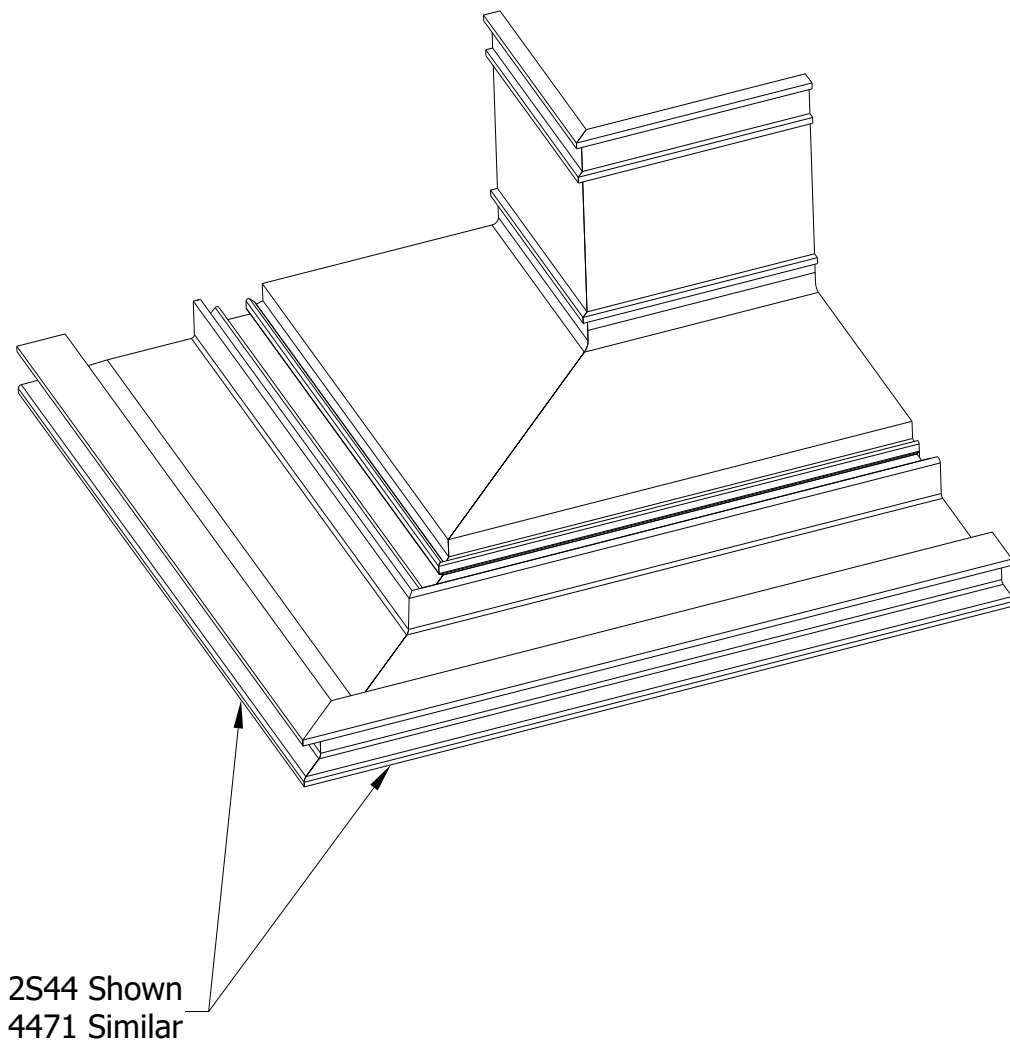

**[FIG. 22]**

## **SECTION VII: Corners**

(Includes Offset and Center-Set Glazing)

### **Corner Identification and Assembly**

Proper identification of the required corner members is necessary to ensure a timely installation process. See details of each corner variation on pages 55 through 57 in Figures 23 through 33.

- |                                     |                                      |
|-------------------------------------|--------------------------------------|
| 23) 90° outside set corner          | 27) 135° outside set corner          |
| 24) 90° inside set corner           | 28) 135° inside set corner           |
| 25) 90° center-set corner           | 29) 135° center-set corner           |
| 26) 90° multiple glass plane corner | 30) 135° multiple glass plane corner |
|                                     | 31) 90° outside set SSG corner       |

Both inside and outside corners can be accommodated with these details. Figures 32 and 33 on page 61 show typical inside corners.

Determine that the subsill has been installed according to the instructions listed on pages 46-51. Ensure the adjacent ladders are built with the appropriate mullion half to be used with the corner mullion. Install the corner member into the subsill. It may be necessary to temporarily brace the vertical corner member until the adjacent ladders are installed and anchored. Install and snap one corner ladder completely, and then install and snap the other onto the corner mullion.

If door openings are required on a run that incorporates a corner member, begin at the doorframe and assemble towards the corner area with the required ladders. Unassembled corner extrusions must be attached to the ladders, and the corner member must be assembled after installation of both adjacent ladders.

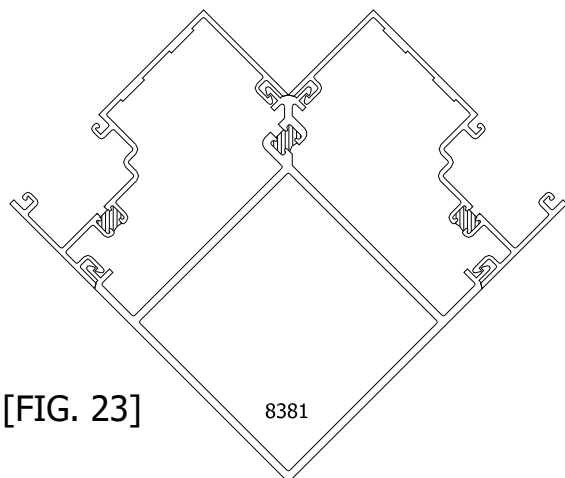

[FIG. 23]

8381

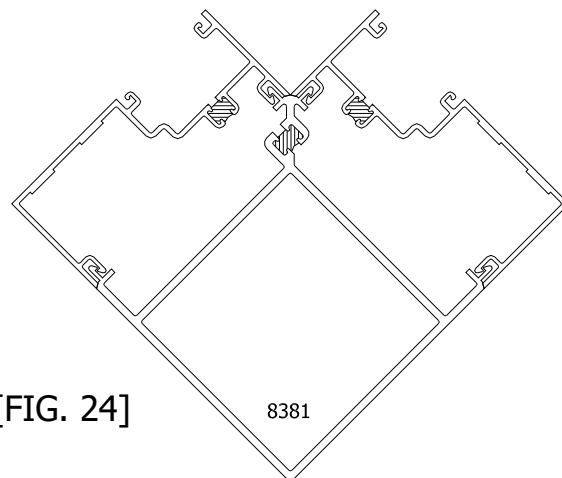

[FIG. 24]

8381

## **SECTION VII: Corners**

(Includes Offset and Center-Set Glazing)

[FIG. 25]

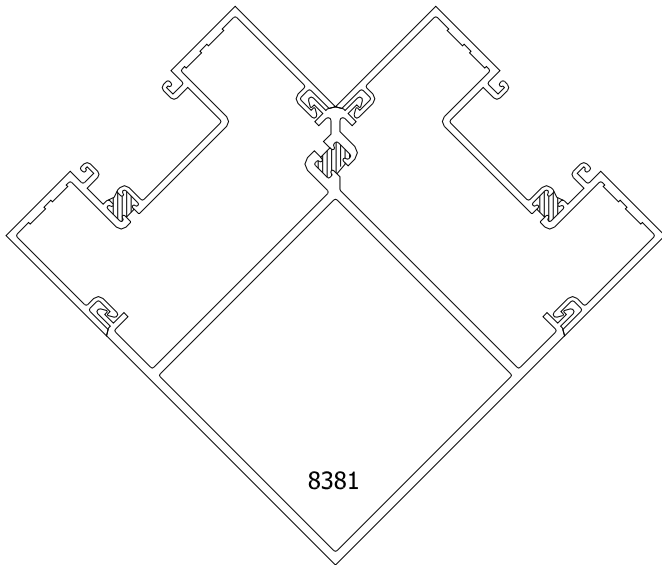

[FIG. 26]

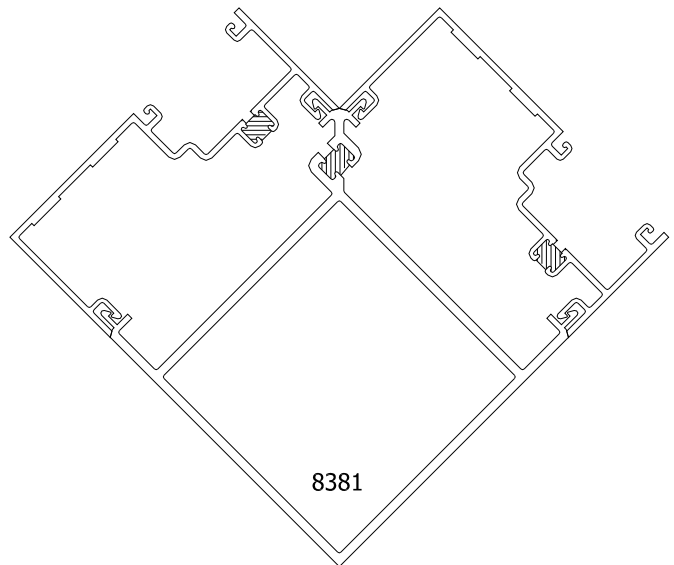

NOTE: Figure 26 shows Inside and Outside set verticals. You can create a multi-plane configuration by using any of the vertical mullions shown in figures 23, 24 and 25.

[FIG. 27]

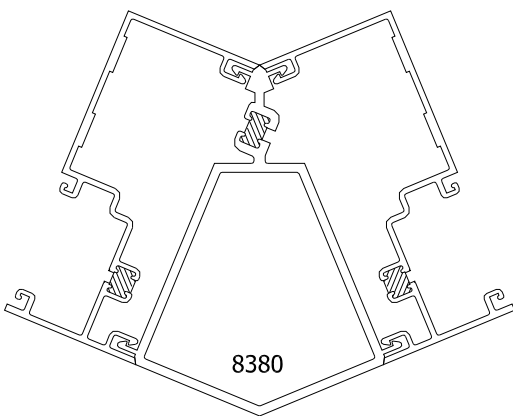

[FIG. 28]

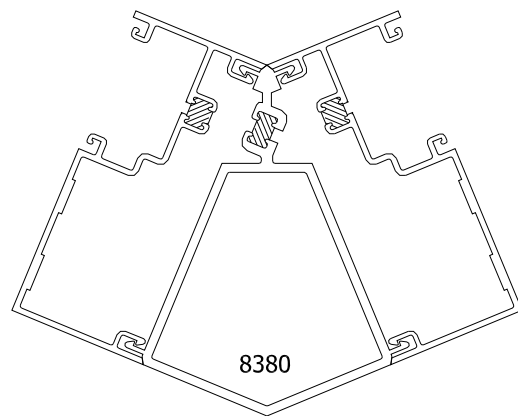

## SECTION VII: Corners

(Includes Offset and Center-Set Glazing)

[FIG. 29]

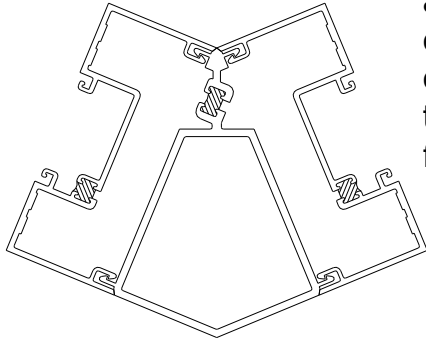

NOTE: Figure 30 shows Inside and Outside set verticals. You can create a multi-plane configuration by using any of the vertical mullions shown in figures 27, 28 and 29.

[FIG. 30]

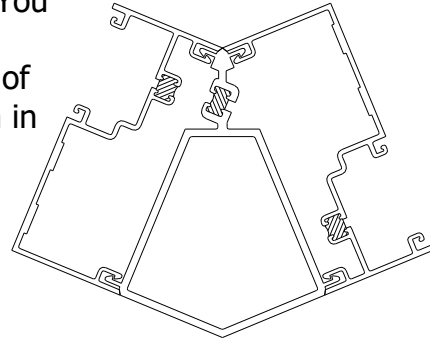

[FIG. 31]

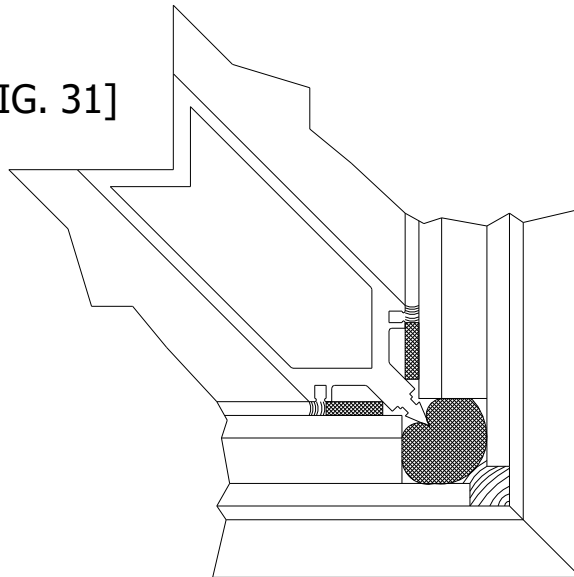

[FIG. 32]

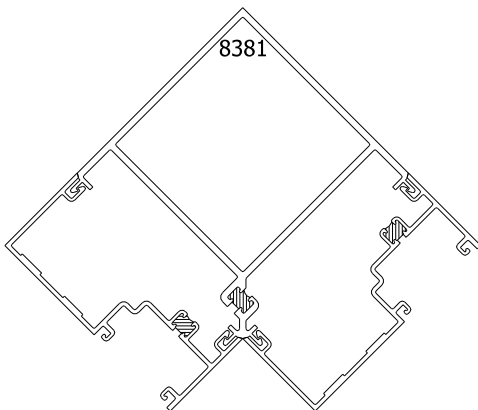

[FIG. 33]

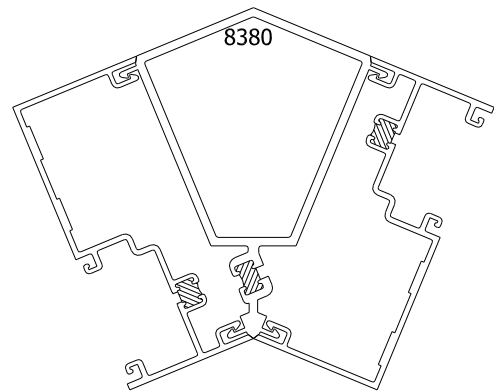

NOTE: Figures 32 and 33 show the typical use of corner mullions as inside corners. All glass planes can be accommodated in both inside and outside corners.

## SECTION VIII: Installation

(Includes Offset and Center-Set Glazing)

### Step 1) Sealing the Sill onto the Subsill

Apply a silicone type sealant to the subsill in the location shown in Figure 34 before installing the first ladder. Make sure that enough sealant is applied to seal the areas shown in Figure 35. After installing the ladder and anchoring it, clean off all excess sealant from exposed areas. Do not allow sealant to cure before placing the system frames. It will interfere with the sill to subsill engagement.

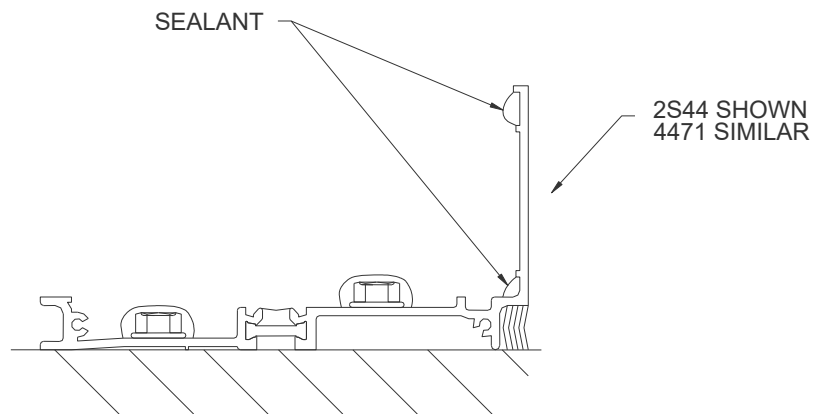

[FIG. 34]

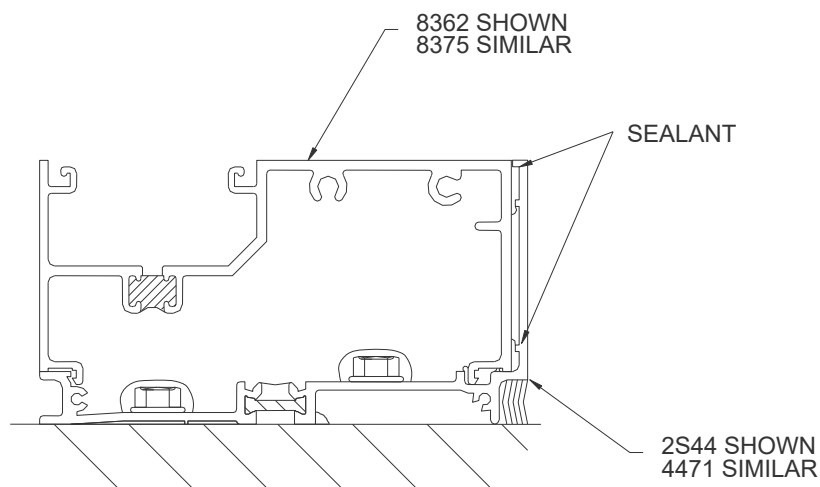

[FIG. 35]

## SECTION VIII: Installation

(Includes Offset and Center-Set Glazing)

### Step 2) Installing Jamb Side Ladder

Place the ladder on the subsill at an approximate 30° angle. While applying pressure upward, rotate the ladder into the condition. See Figure 35 on page 58 for sill placement into the subsill. When rotated correctly, the exterior face of the sill should be flush with the exterior face of the subsill.

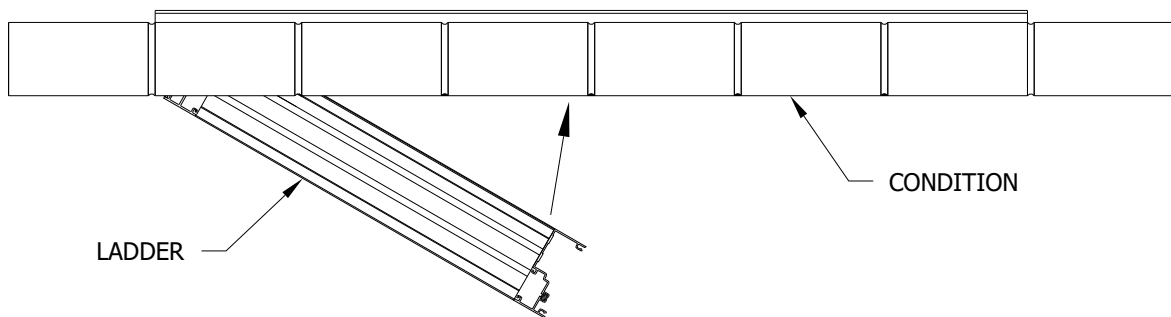

[FIG. 36]

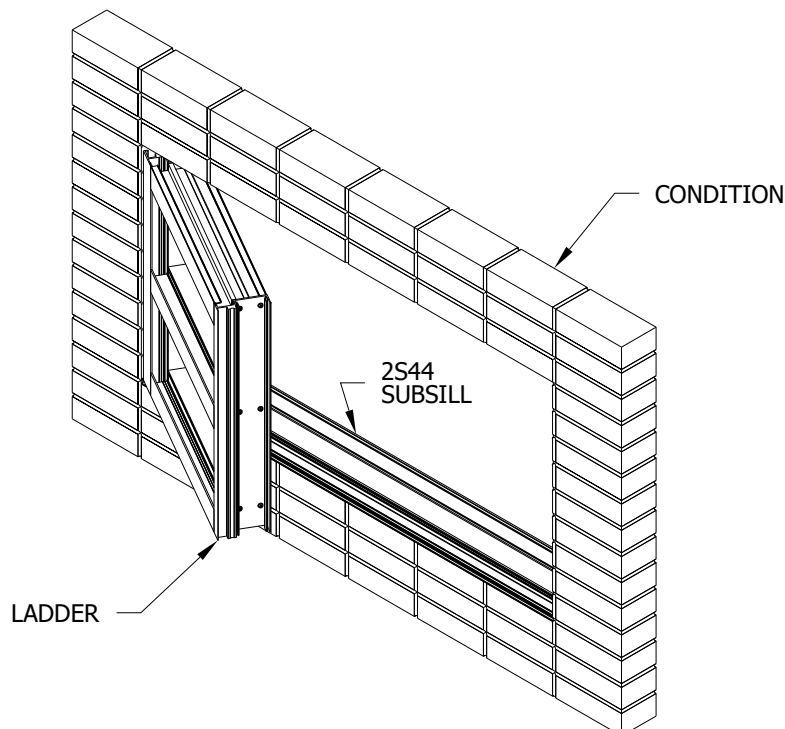

[FIG. 37]

## SECTION VIII: Installation

(Includes Offset and Center-Set Glazing)

### Step 3) Anchoring the Head

For D.L.O.s 36" and narrower, the anchors must be spaced 6" from the jamb or vertical members. For D.L.O.s 36" and wider, the outside anchors must be spaced 6" from the jamb with the center anchor centered on the D.L.O. See Figure 38 below.

**These recommendations are for general erection procedures only. For actual job conditions, see the details on the shop drawings. For perimeter anchor type and spacing, refer to the approved shop drawings or consult the project design professional.**

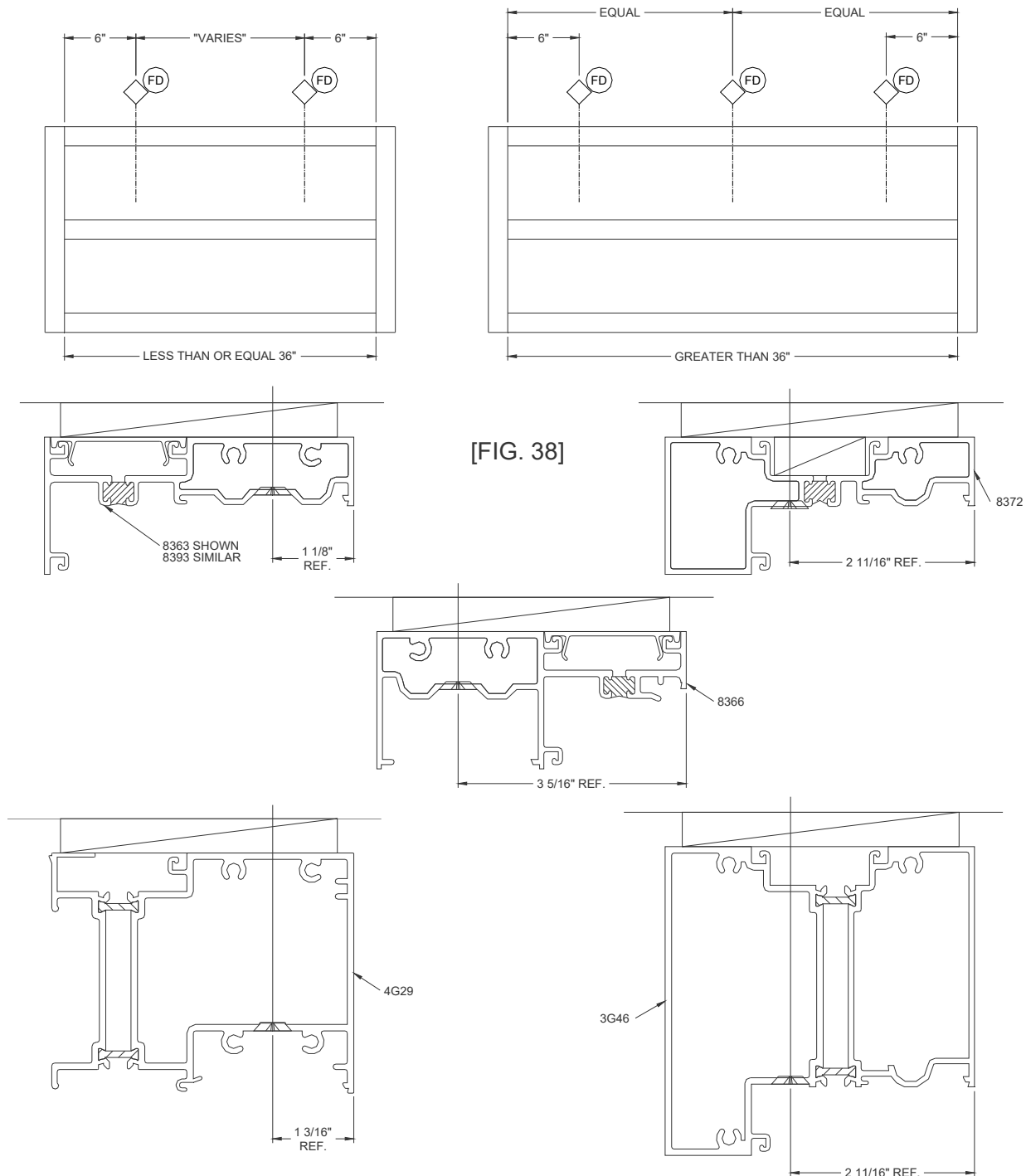



## SECTION VIII: Installation

(Includes Offset and Center-Set Glazing)

### Step 4) Anchoring the Jambs

Anchors must be spaced 6" from the sill or head, and 24" O.C.  $\pm$  4", so they do not interfere with the horizontal members. See Figure 42. Regardless of glass pocket configuration, the anchors should be placed so they do not fasten through the thermal area. See Figures 43 through 46.

**These recommendations are for general erection procedures only. For actual job conditions, see the details on the shop drawings. For perimeter anchor type and spacing, refer to the approved shop drawings or consult the project design professional.**

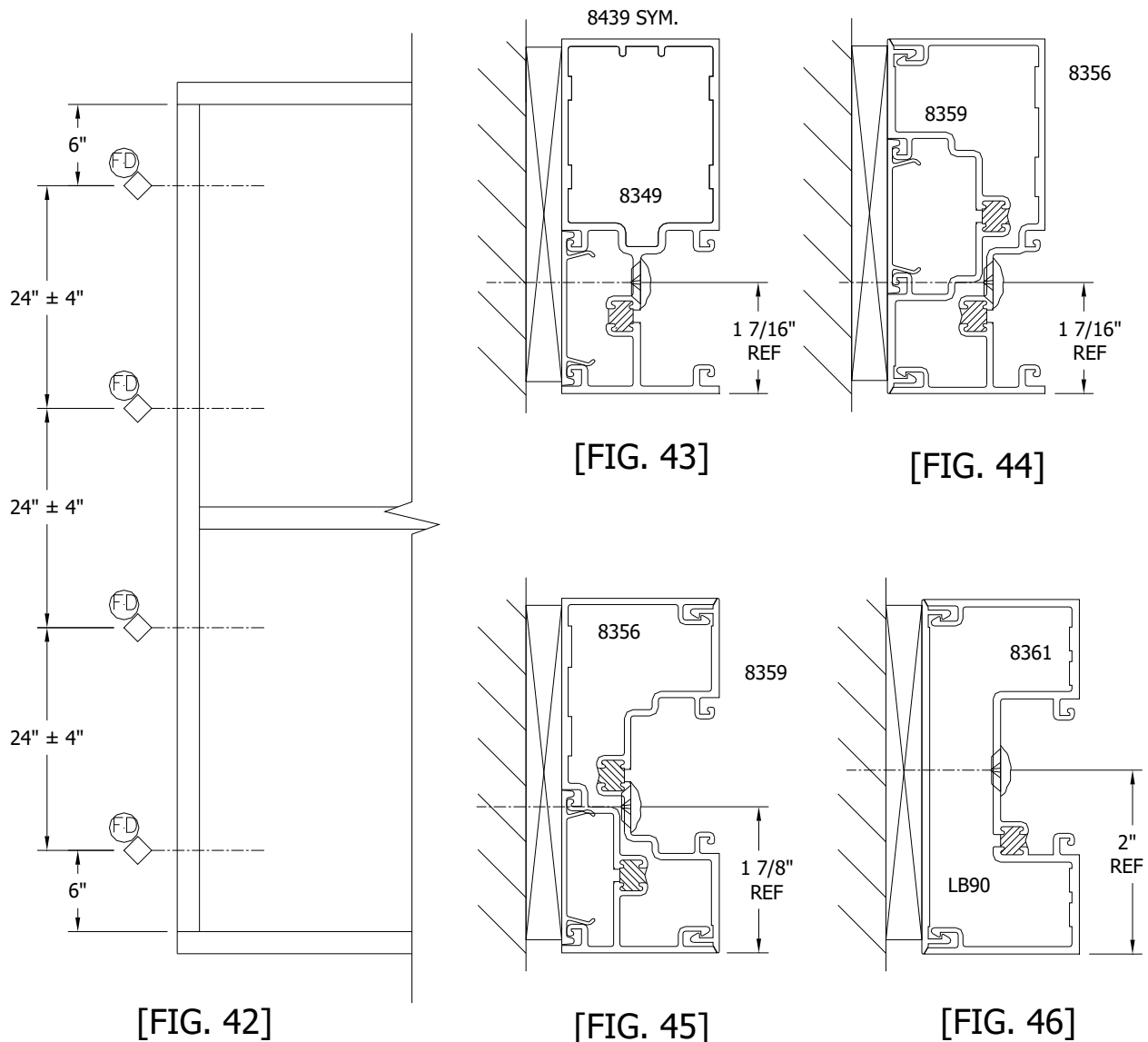

## SECTION VIII: Installation

(Includes Offset and Center-Set Glazing)

### Step 5) Sealing Vertical Mullions

Prior to installing an intermediate vertical mullion or perimeter jamb, apply silicone type sealant to the vertical mullion in the location shown in Figure 47 below at the Interior joints only. Apply sealant where indicated 6-8 inches up from the bottom of the vertical joints. Apply enough sealant so when the filler or opposite mullion half is snapped, it will create a good seal. Wipe off excess sealant from the exposed Interior of the frame. This sealant practice should be followed for all variations of vertical mullions including corners and perimeter jambs, except where a perimeter mullion uses vinyl filler. See Figures 48 through 54.

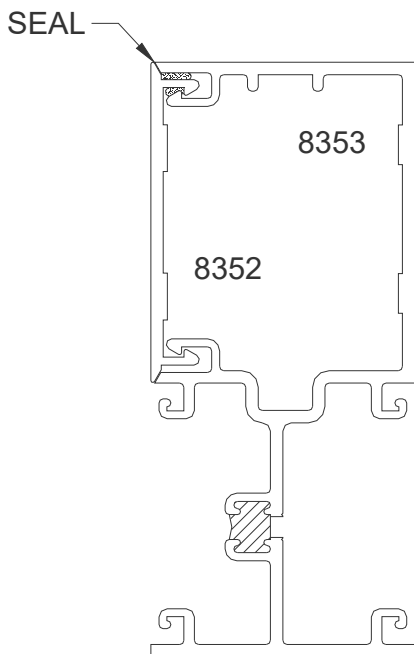
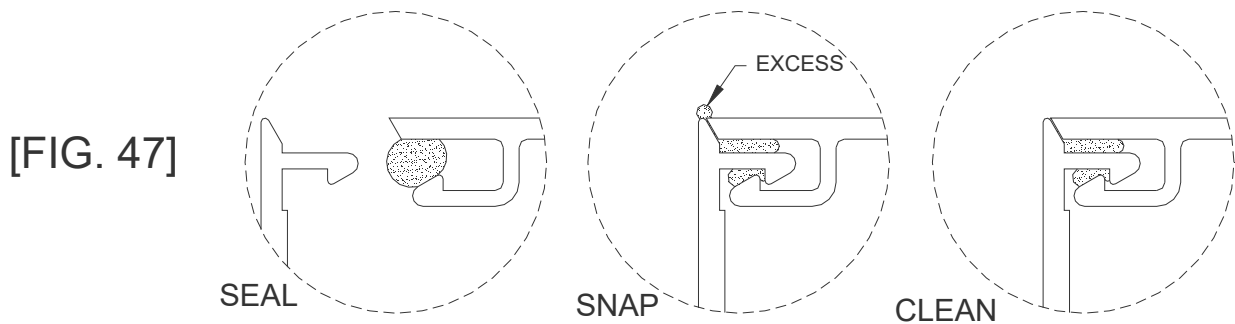

[FIG. 48]

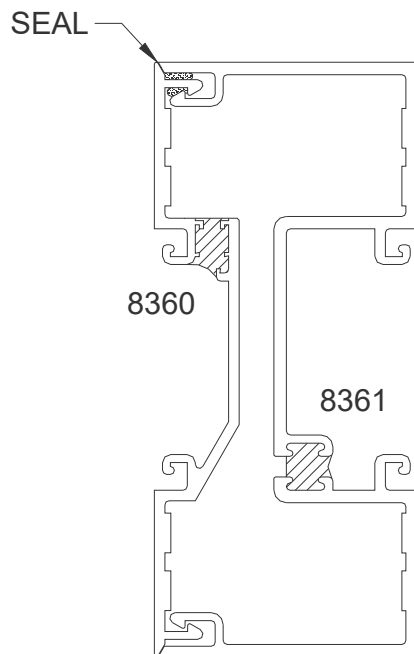

[FIG. 49]

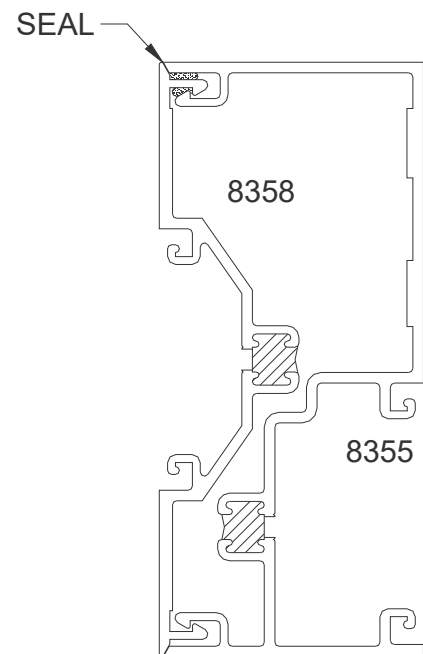

[FIG. 50]

# SECTION VIII: Installation

(Includes Offset and Center-Set Glazing)

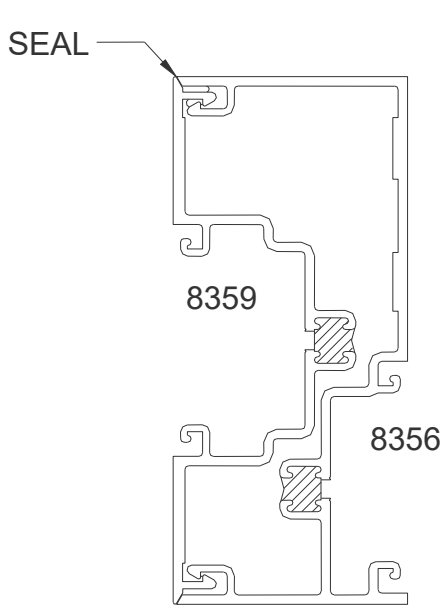

[FIG. 51]

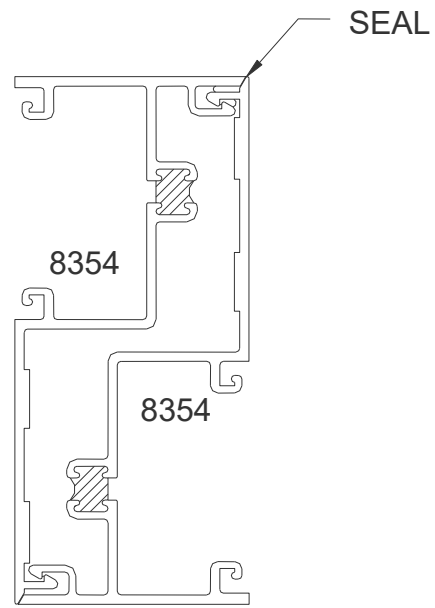

[FIG. 52]

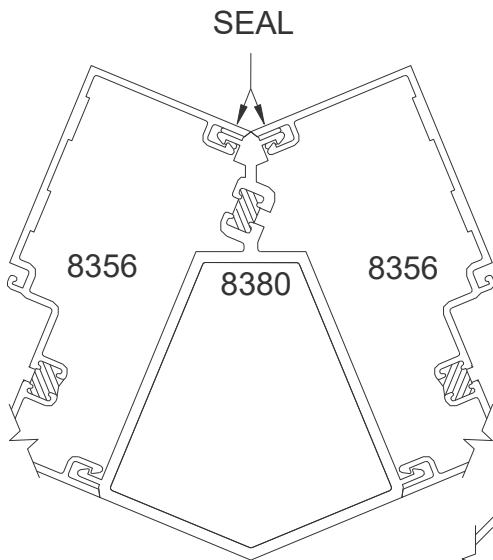

[FIG. 53]

8356 SHOWN IN CORNER MULLIONS, OTHERS SIMILAR.

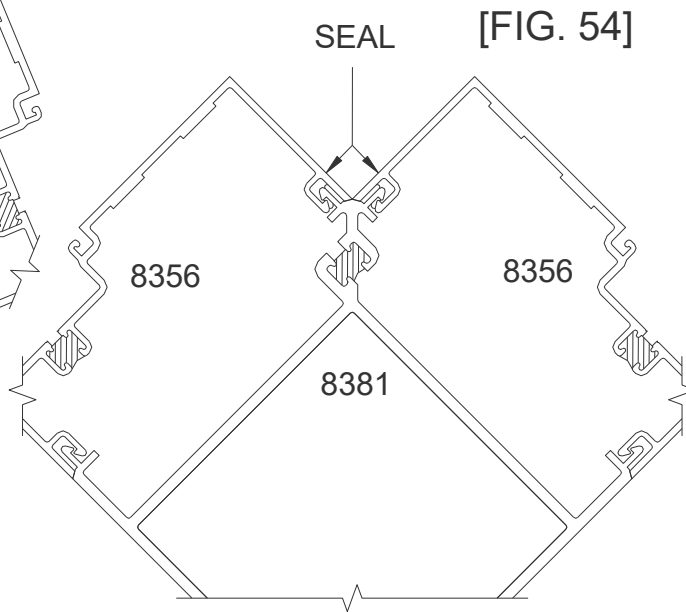

[FIG. 54]

Seal Vertical 6"-8" from the bottom up.

## SECTION VIII: Installation

(Includes Offset and Center-Set Glazing)

### Step 6) Installing the Second Ladder

Make sure that the anchors are installed into the head and jamb of the first ladder. Apply the sealant as specified in Figures 47 through 54 on pages 66 and 67. Apply sealant to the subsill as shown on page 40. Place the second ladder on the subsill at an approximate 30° angle. Rotate the ladder into the condition approximately 1/4" away from the previously installed ladder.

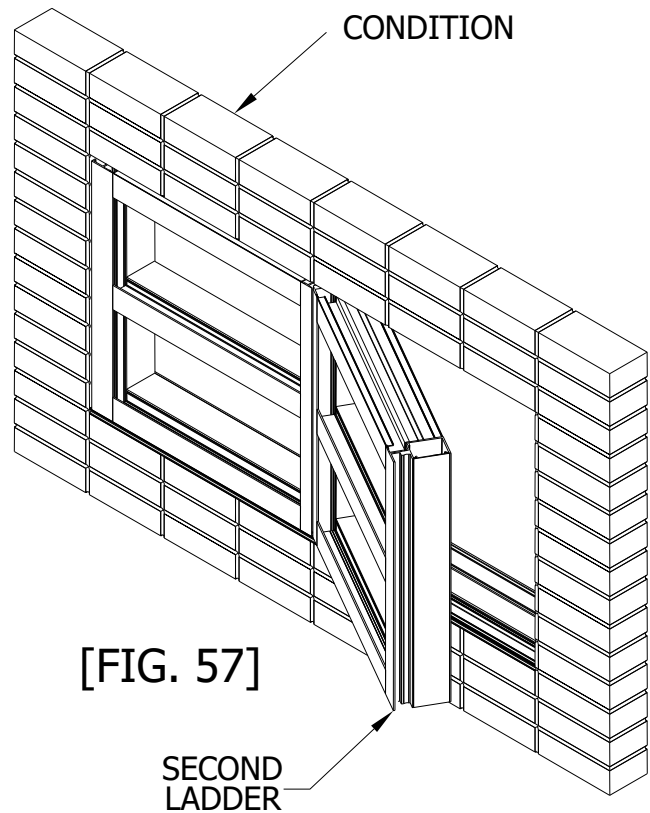
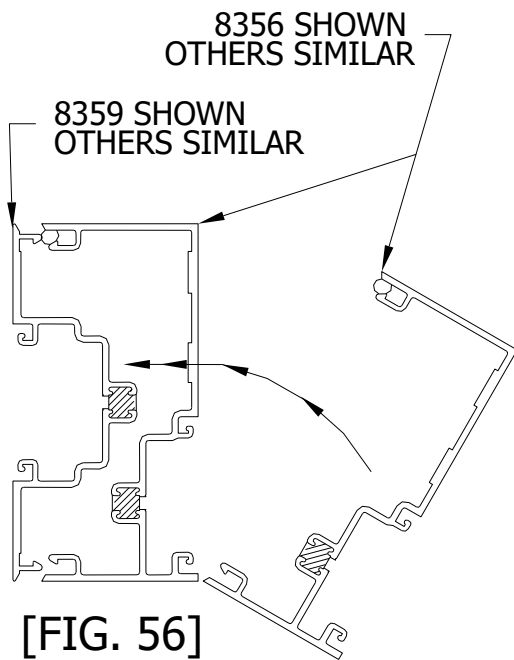
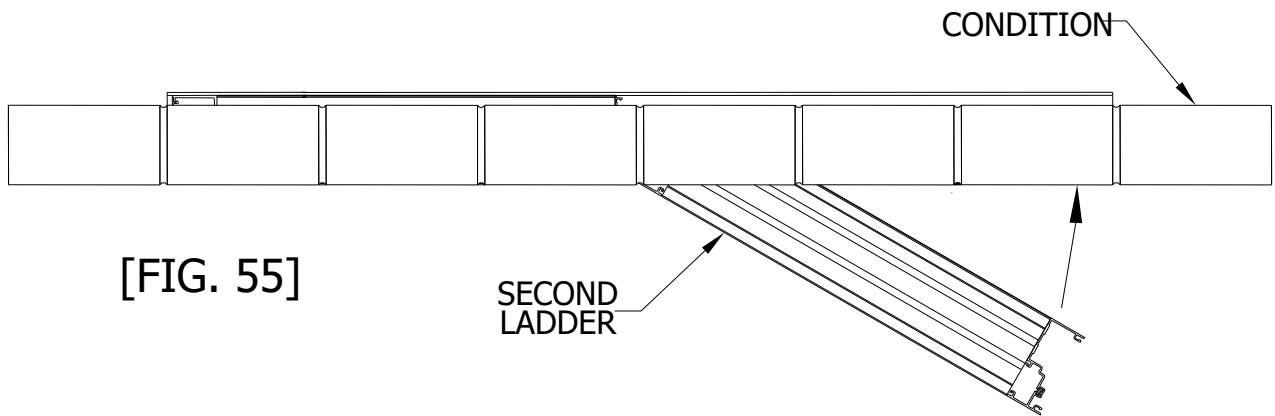

## SECTION VIII: Installation

(Includes Offset and Center-Set Glazing)

### Step 7) Snapping Vertical Mullions Together

To snap vertical mullions together, line up the mullion halves once the 1/4" gap is achieved between the mullion halves. See Figure 56 on page 64. Place one clamp at the bottom of the mullions using wood blocks to protect the extrusions. Tighten the clamp until the mullion halves begin to snap together. Place another set of wood blocks and a clamp at the middle of the mullions and tighten it. Then repeat the same process on the top. Tighten the clamps until the mullion halves are pressed together. The sight line should be 2". It may be necessary to work from one clamp to the next several times, or move the clamps, to ensure the mullions are snapped together evenly. See Figure 59. **DO NOT** try to hammer the mullion halves together! This will dent, bend, scratch, or deform the mullions and may cause them to leak. Ensure that the previous ladder is anchored using the requirements on page 60 before installing the 2nd ladder.

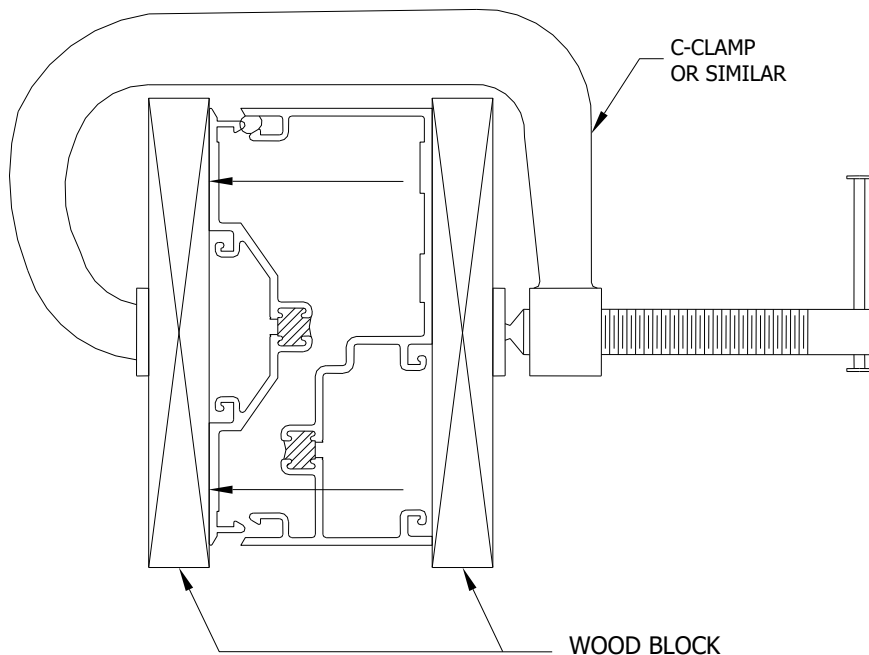

[FIG. 58]

8358/8355 SHOWN,  
OTHERS SIMILAR

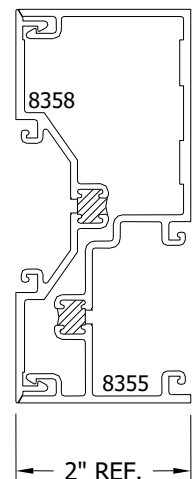

[FIG. 59]

## **SECTION VIII: Installation**

(Includes Offset and Center-Set Glazing)

### **Step 8) Snapping the Expansion Mullion (Offset Mullion)**

To snap the expansion mullion together, line up the mullion halves and gaskets. See Figure 60. Place one clamp at the bottom of the expansion mullion using wood blocks to protect the extrusions. Tighten the C-clamp until the expansion mullion halves begin to snap together. Place another set of wood blocks and a C-clamp at the middle of the expansion mullion and tighten it. Then repeat the same process on the top. Tighten the C-clamps until the sight line becomes 2 1/4". It may be necessary to work from one clamp to the next several times, or move the clamps to ensure the mullions are snapped together evenly. See Figure 61. DO NOT try to hammer the expansion mullion together! This will dent, bend, scratch, or deform the expansion mullion and may cause it to leak. Anchor the head using the requirements shown on page 64 before installing the next ladder. If this is the last ladder, anchor the jambs as required on page 65 and proceed to the perimeter sealing process, Step 11 on page 72.

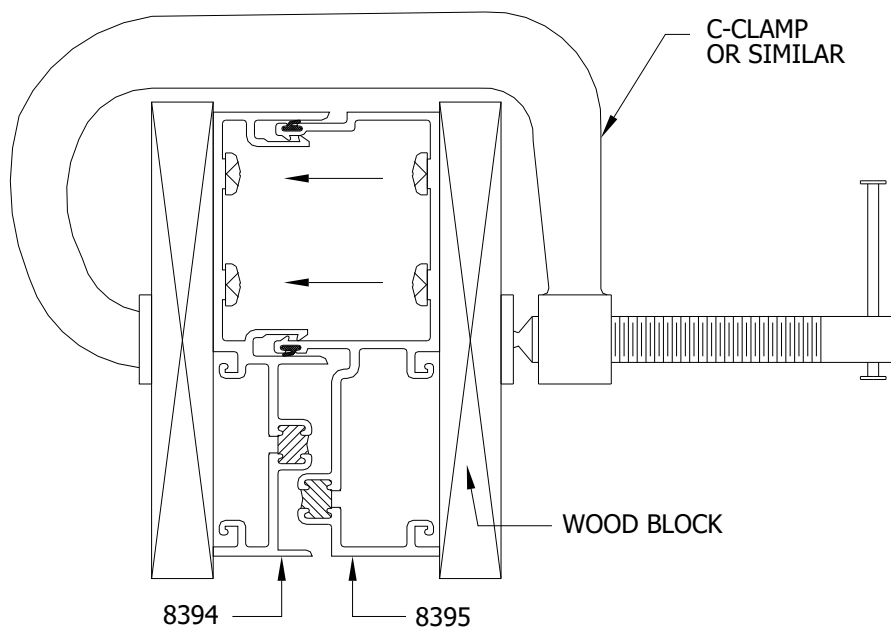

**[FIG. 60]**

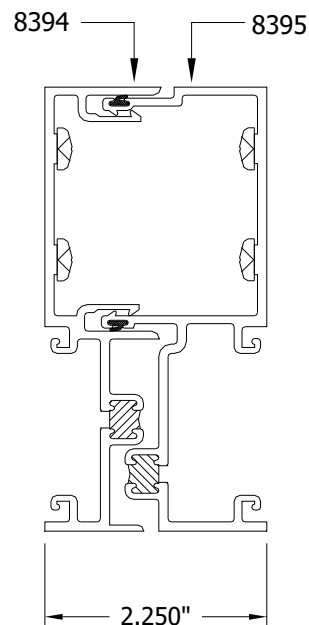

**[FIG. 61]**

## **SECTION VIII: Installation**

(Includes Offset and Center-Set Glazing)

### **Step 9) Snapping the Expansion Mullion (Center-Set Mullion)**

To snap the expansion mullion together, line up the mullion halves and gaskets. See Figure 62. Place one clamp at the bottom of the expansion mullion using wood blocks to protect the extrusions. Tighten the C-clamp until the expansion mullion halves begin to snap together. Place another set of wood blocks and a C-clamp at the middle of the expansion mullion and tighten it. Then repeat the same process on the top. Tighten the C-clamps until the sight line becomes 2". It may be necessary to work from one clamp to the next several times, or move the clamps, to ensure the mullions are snapped together evenly. See Figure 63. DO NOT try to hammer the expansion mullion together! This will dent, bend, scratch, or deform the expansion mullion and may cause it to leak. Anchor the head using the requirements shown on page 64 before installing the next ladder. If this is the last ladder, anchor the jambs as required on page 65 and proceed to the perimeter sealing process, Step 11 on page 72.

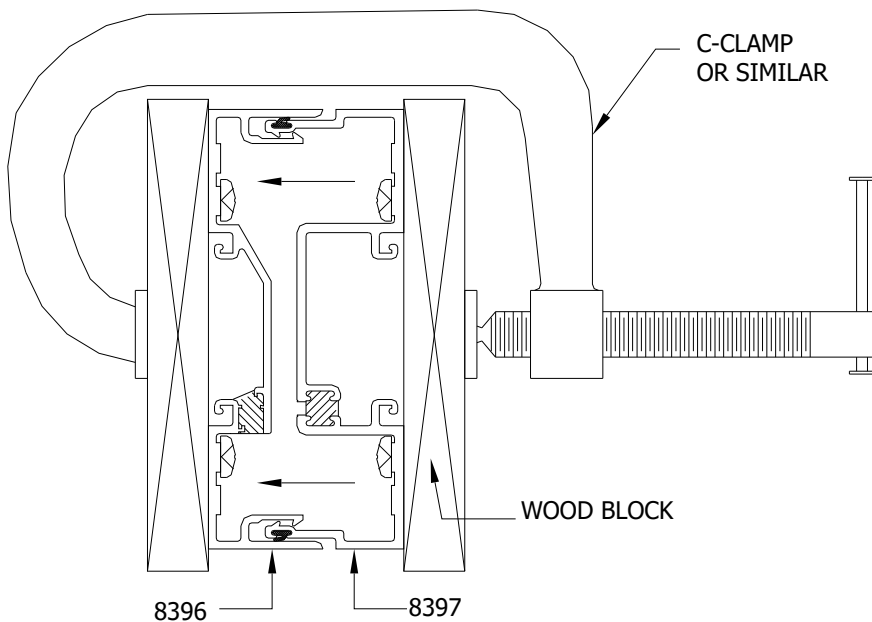

[FIG. 62]

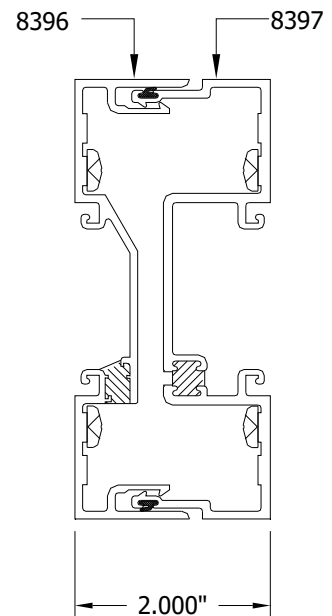

[FIG. 63]

## SECTION VIII: Installation

(Includes Offset and Center-Set Glazing)

### Step 10) Anchoring the Second Ladder

After the mullion halves are snapped correctly, ensure that the mullions are plumb and true and anchor the head as shown in Figure 38 on page 64. If this is the last ladder in a run, ensure that the mullion halves are snapped correctly and install the required shims between the jamb and condition. Install the head and jamb anchors. Ensure that the jamb anchors do not separate the last ladder from the previous. It may be necessary to shim tightly against the condition to prevent this.

### Step 11) Perimeter Seal

When the unit is installed and anchored, begin placing caulk rope into the gap between the perimeter and the frame. Apply a generous amount of silicone type sealant to the gap between the frame and rough opening. Tool off all excess sealant to ensure a good seal and to achieve an appropriate appearance. See Figures 64 through 68 below.

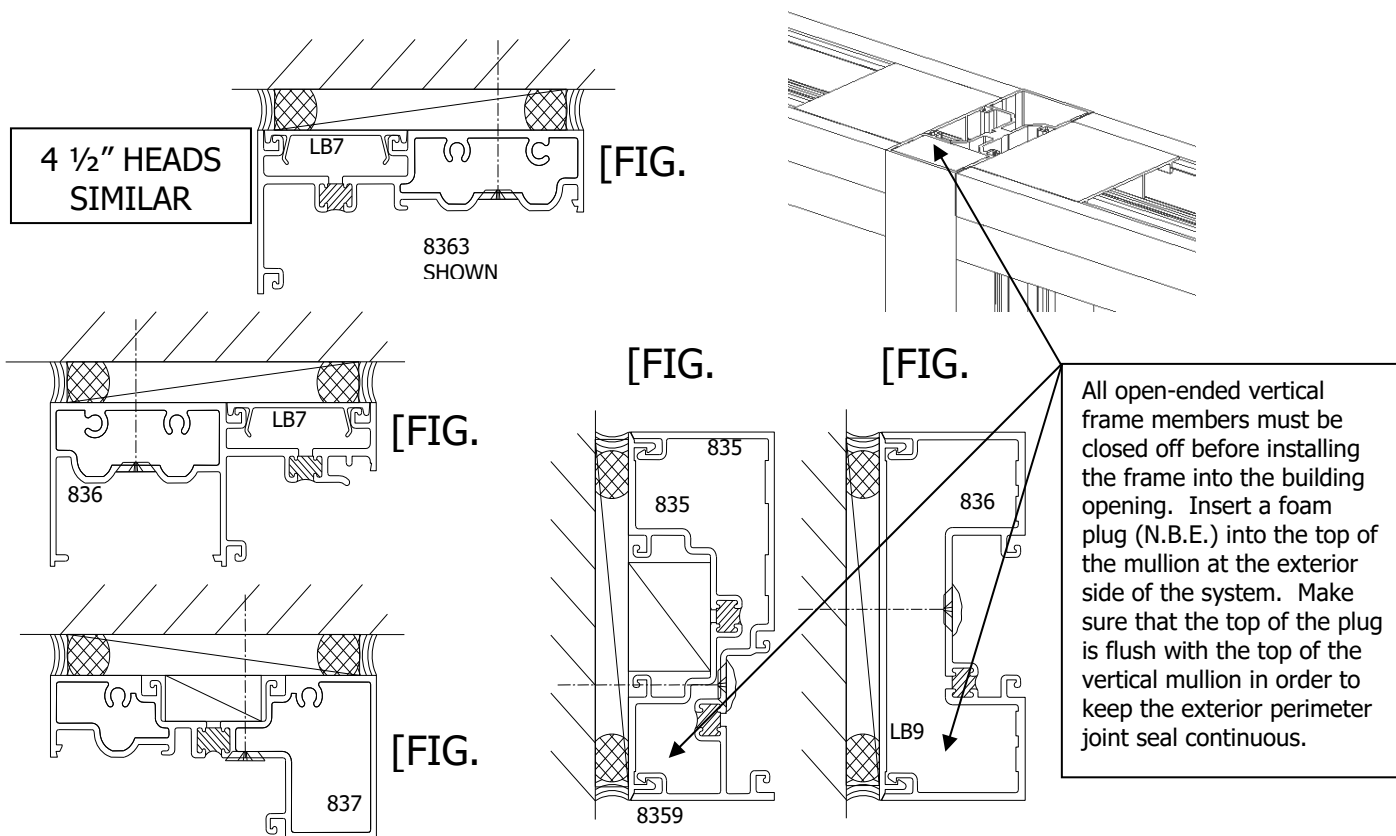



# SECTION IX: Glazing

(Includes Offset and Center-Set Glazing)

## IDENTIFICATION OF GLASS POCKETS AND SETTING BLOCKS

### INSIDE GLAZED HORIZONTALS

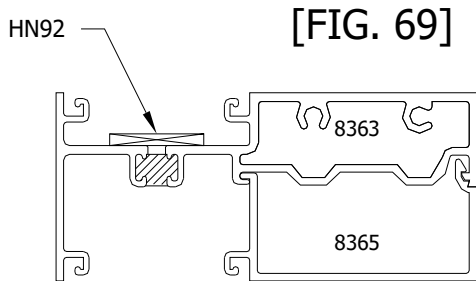

[FIG. 70]

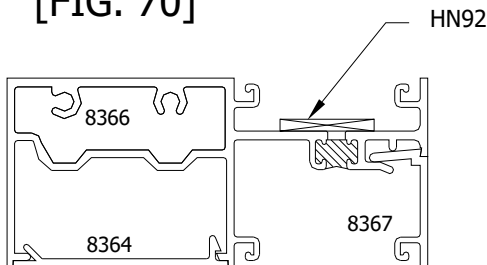

[FIG. 71]

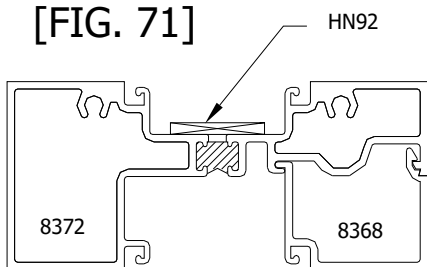

### INSIDE GLAZED SILLS

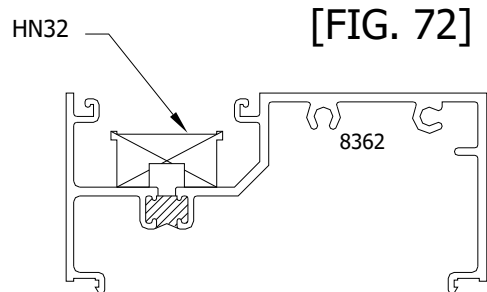

[FIG. 73]

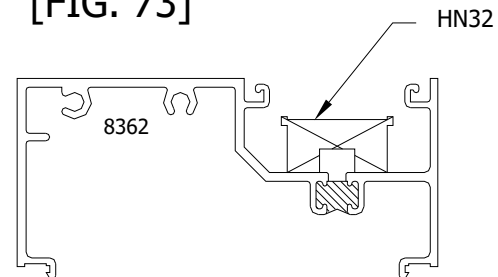

[FIG. 74]

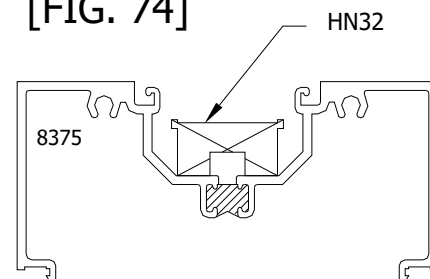

4 1/2" SILLS &  
HORIZONTALS  
SIMILAR

**Customer / Installer Note:**

**EFCO setting blocks are typically 4" in length with different depths. If the glazing infill is "NOT BY EFCO" and glazing sizes are larger than 40 square feet, then the glazing details must be reviewed by the glazing manufacturer for proper setting block size.**

**SECTION IX: Glazing**

(Includes Offset and Center-Set Glazing)

**IDENTIFICATION OF GLASS POCKETS AND SETTING BLOCKS**

**OUTSIDE GLAZED HORIZONTALS**

**OUTSIDE GLAZED SILLS**

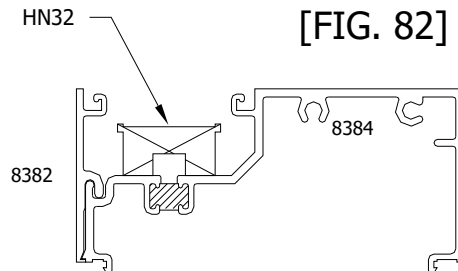
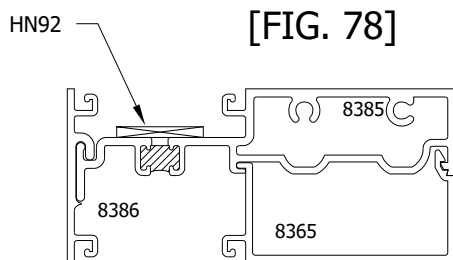
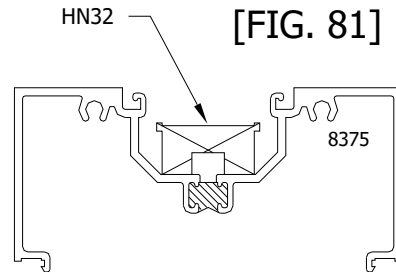
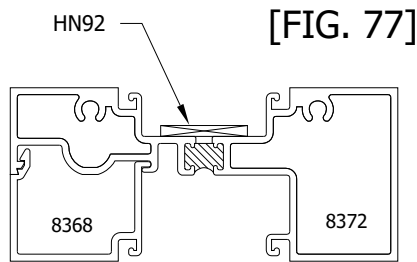
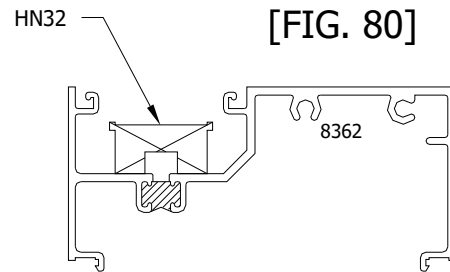
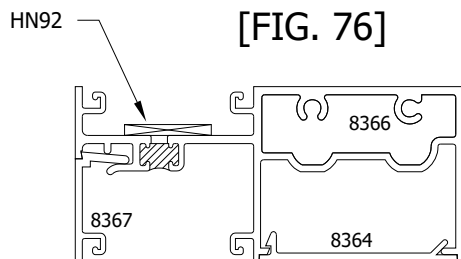
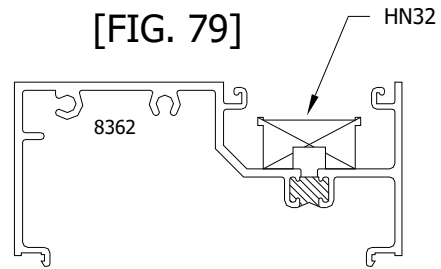
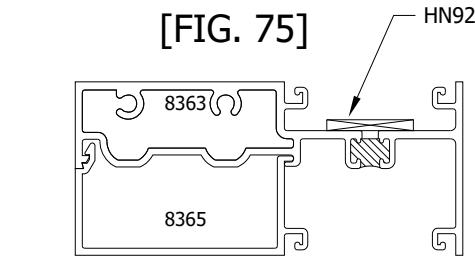

**Customer / Installer Note:**  
**EFCO setting blocks are typically 4" in length with different depths. If the glazing infill is "NOT BY EFCO" and glazing sizes are larger than 40 square feet, then the glazing details must be reviewed by the glazing manufacturer for proper setting block size.**

**4 1/2" SILLS & HORIZONTALS SIMILAR**

## SECTION IX: Glazing

(Includes Offset and Center-Set Glazing)

### Step 1) Identification of Glass Pockets

#### INSIDE AND OUTSIDE GLAZED VERTICALS

Ensure that each vertical DLO has at least one DEEP glass pocket on either side. It is necessary for the glazing installation that a deep pocket be used to load the glazing units. These details are shown with the deep glazing pockets shown right justified for viewing clarity.

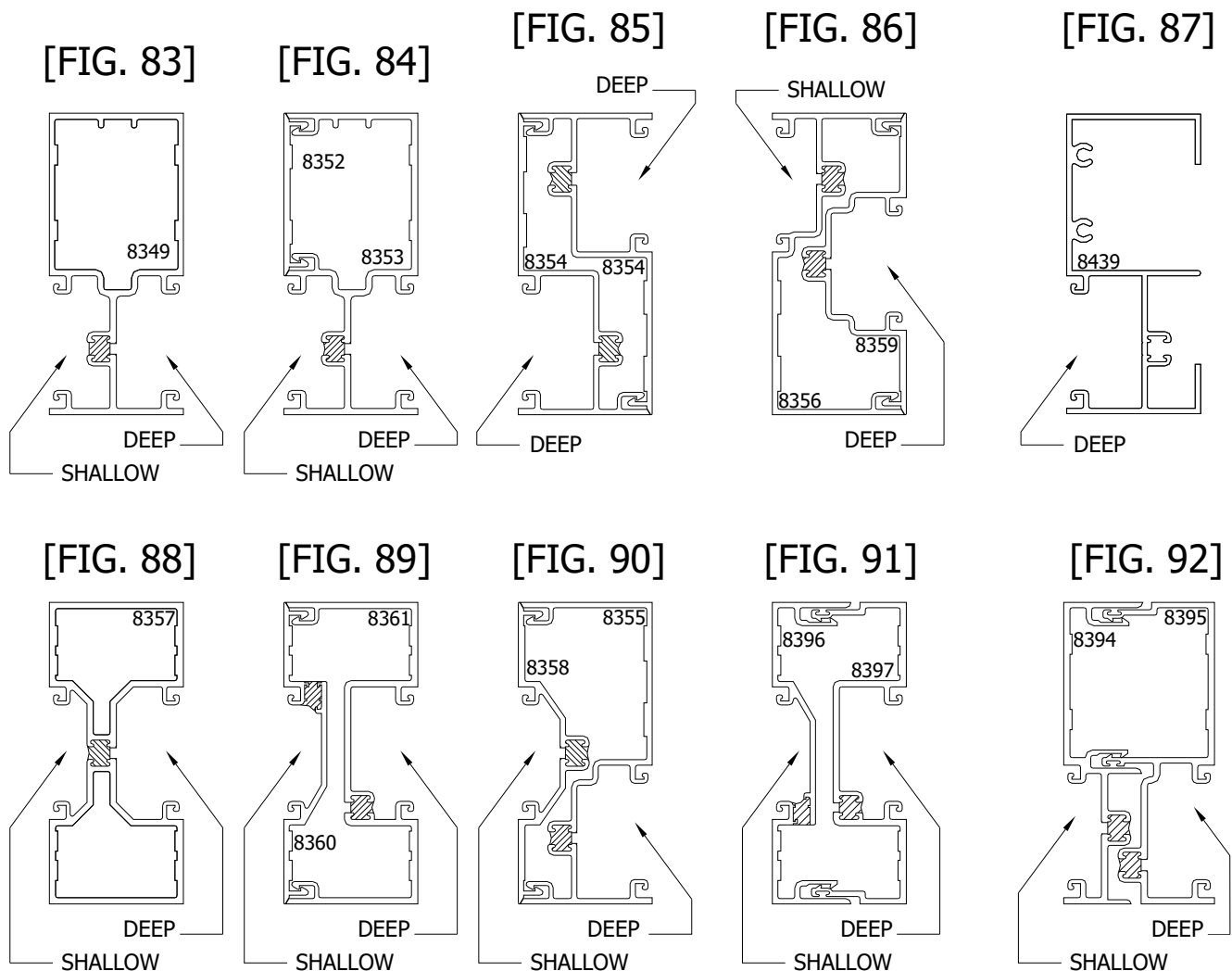

## SECTION IX: Glazing

(Includes Offset and Center-Set Glazing)

### Step 2) Glass Size Formulas

For captured glazing variations, the glass size formula is  $DLO + 7/8"$ . For structural glaze systems the glass size formula is  $DLO + 1\ 1/2"$ . The glass size formula from captured mullion to SSG mullion is  $DLO + 1\ 3/16"$ . From SSG mullion to SSG mullion the glass size formula is  $DLO + 1\ 1/2"$ . Captured mullions have a glass bite of  $7/16"$ . SSG mullions have a glass bite of  $3/4"$ .  $90^\circ$  SSG corners use offset glass with the interior glass size and the exterior glass size being different (see Figure 94). Refer to Figures 93, 94, and 95 below.

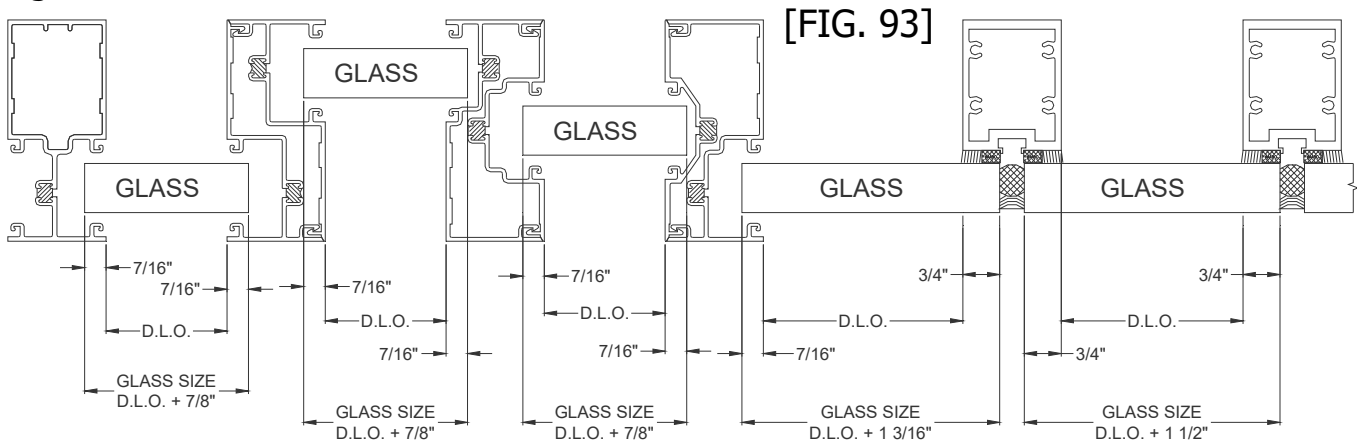

Note that the  $90^\circ$  SSG mullions have glass that utilizes dual width glazing. Glass sizes should be specified using the interior & exterior glass formulas shown in Figure 94.

4 1/2" SILLS & HORIZONTALS SIMILAR

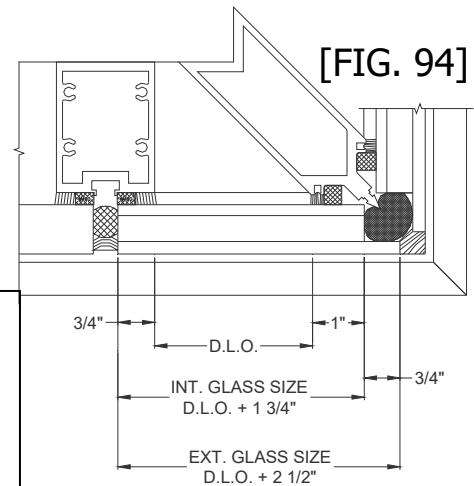

**Customer / Installer Note:**  
**EFCO setting blocks are typically 4" in length with different depths. If the glazing infill is "NOT BY EFCO" and glazing sizes are larger than 40 square feet, then the glazing details must be reviewed by the glazing manufacturer for proper setting block size.**

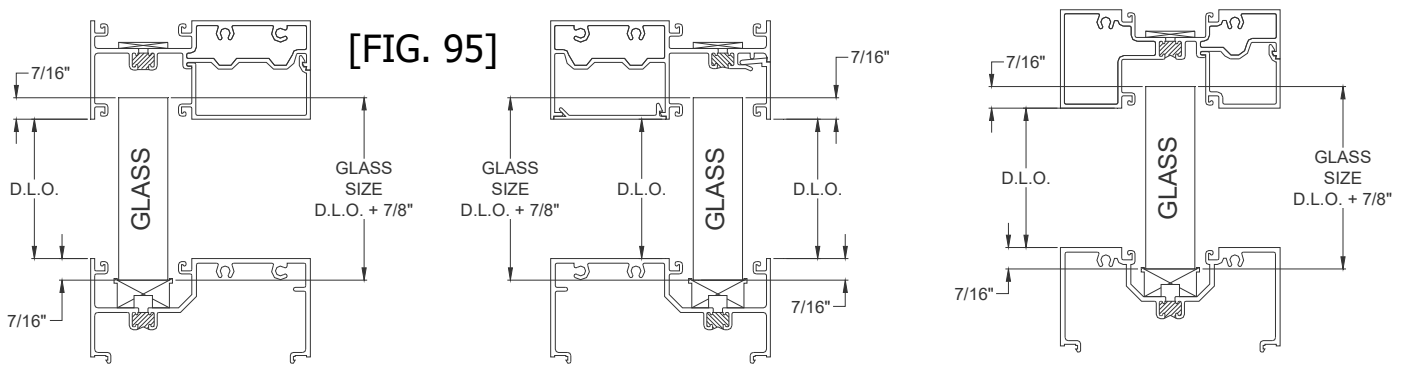

**VERTICAL GLASS SIZE DOES NOT CHANGE WHEN SSG MULLIONS ARE USED.**

## SECTION IX: Glazing

(Includes Offset and Center-Set Glazing)

### Step 3) Installing the Water Deflector

#### HWD1 - WATER DEFLECTOR

The HWD1 water deflector is designed to be universal. It may need to be modified to fit certain glazing pockets. Install the HWD1 at the ends of the intermediate horizontals only. It is not required at heads or sills. Use a silicone type sealant to adhere the HWD1 onto the intermediate horizontal. Ensure that the HWD1 fits flush with the top of the intermediate horizontal glazing pocket and smooth any excess silicone sealant so water will flow easily over the water deflector.

[FIG. 96]

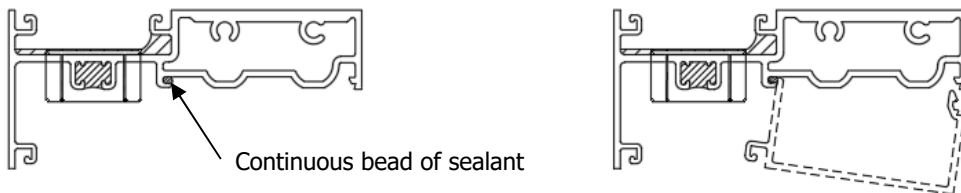
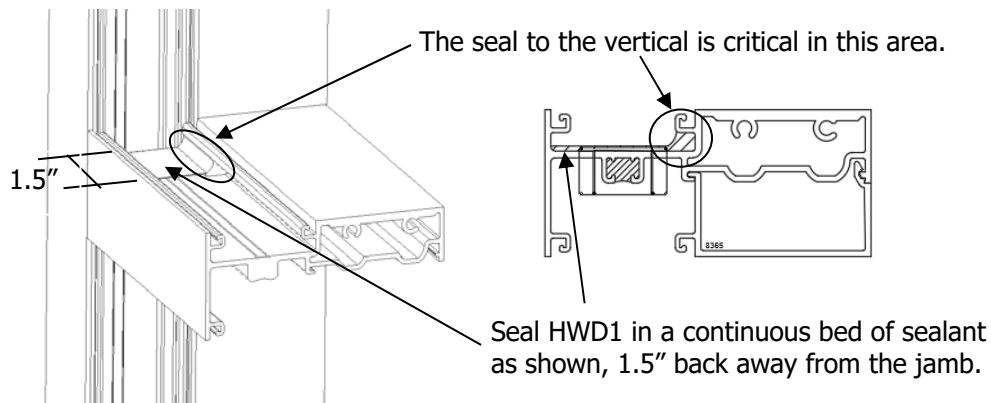
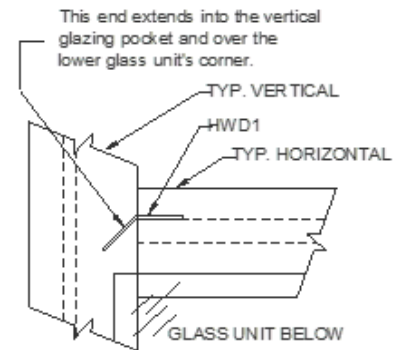

Glass Stop - Ensure that the glass stop hook is clean and free of oil and dirt. Run a continuous bead of silicon at area shown above.

Before sealant cures, place stop as shown and rotate into final position as shown to the right. Strong hand pressure or a slight tap with a mallet will ensure the glass stop is fully engaged. This step is for both outside and inside glazed units.

### Step 3A) Installing the Water Diverter

#### FW33 - WATER DIVERTER

Install the FW33 at the intermediate horizontals only. It is not required at heads or sills. Use a silicone type sealant to adhere the FW33 onto the intermediate horizontal. Ensure that the FW33 fits flush with the top of the intermediate horizontal glazing pocket and smooth any excess silicone sealant as shown in Figure 97 so water will flow easily over the water deflector.

Apply silicone type sealant across the horizontal mullions before installing the FW33.

Press the water diverter into the sealant and apply a bead of sealant to the perimeter seam. Tool into the horizontal and vertical to achieve a watertight seal at the diverter.

[FIG. 97]

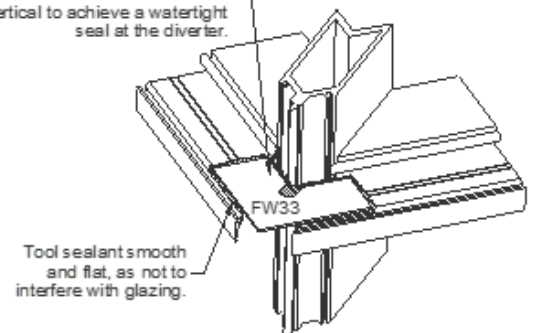

**Step 3B) Installing SSG Horiz. Mullion Bridge Assembly**

**K895 – SSG BRIDGE ASSEMBLY**

Install K895 at the intermediate horizontals only. It is not required at heads or sills. Use a silicone type sealant to adhere the K895 onto the intermediate horizontal. Ensure that the K895 fits flat on top of the intermediate horizontal glazing pocket and smooth any excess silicone sealant as shown in Figure 99 so water will flow easily over the water deflector.

Apply silicone type sealant to the ends of horizontals and across S.S.G. mullion before installing the bridge assembly.

Press the bridge assembly into the sealant and apply a bead of sealant to the perimeter seam of the bridge. Tool into the horizontal and vertical to achieve a water seal at the bridge.

Tool sealant smooth and flat, as not to interfere with glazing.

[FIG. 98]

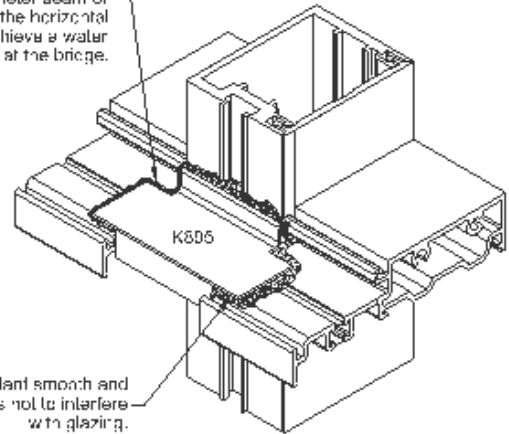

**Step 4) Installing Glass Blocks**

Glass blocks for the 433 system are designed to be used at 1/4 points and 1/8 points for special dead load applications. For intermediate horizontals, use glass block HN92. For sills, use glass block HN32. It may be necessary to use a small amount of sealant on the bottom of the glass blocks to ensure they remain in the intended position. Refer to Figure 100 below for 1/4 point and 1/8 point verification.

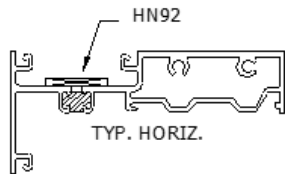

[FIG. 99]

4 1/2" SILLS & HORIZONTALS SIMILAR

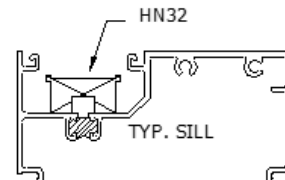

OUTSIDE SET, INSIDE GLAZED SHOWN. OTHERS ARE SIMILAR

[FIG. 100]

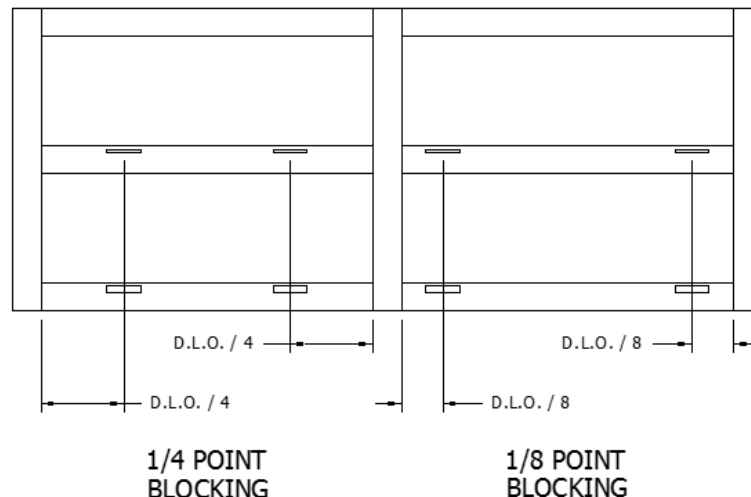

## SECTION IX: Glazing

(Includes Offset and Center-Set Glazing)

### Step 5) Installation of Glazing Gasket

For inside glazed applications, install the exterior gasket prior to glass installation. For outside glazed applications, install the interior gasket prior to glass installation.

SIZE THE GASKET LENGTH BY USING THE FOLLOWING FORMULA.

$$\text{D.L.O.} + 3.0''$$

NOTE: To install glazing gasket, start by pushing the gasket in place at the ends. Move to the middle, then to quarter points and work the "waves" toward the ends. Do not stretch the gasket or it will return to its original form, creating gaps at the gasket intersection. (Gasket length=D.L.O. + 3.0")

See Figure 101 below.

[FIG. 101]

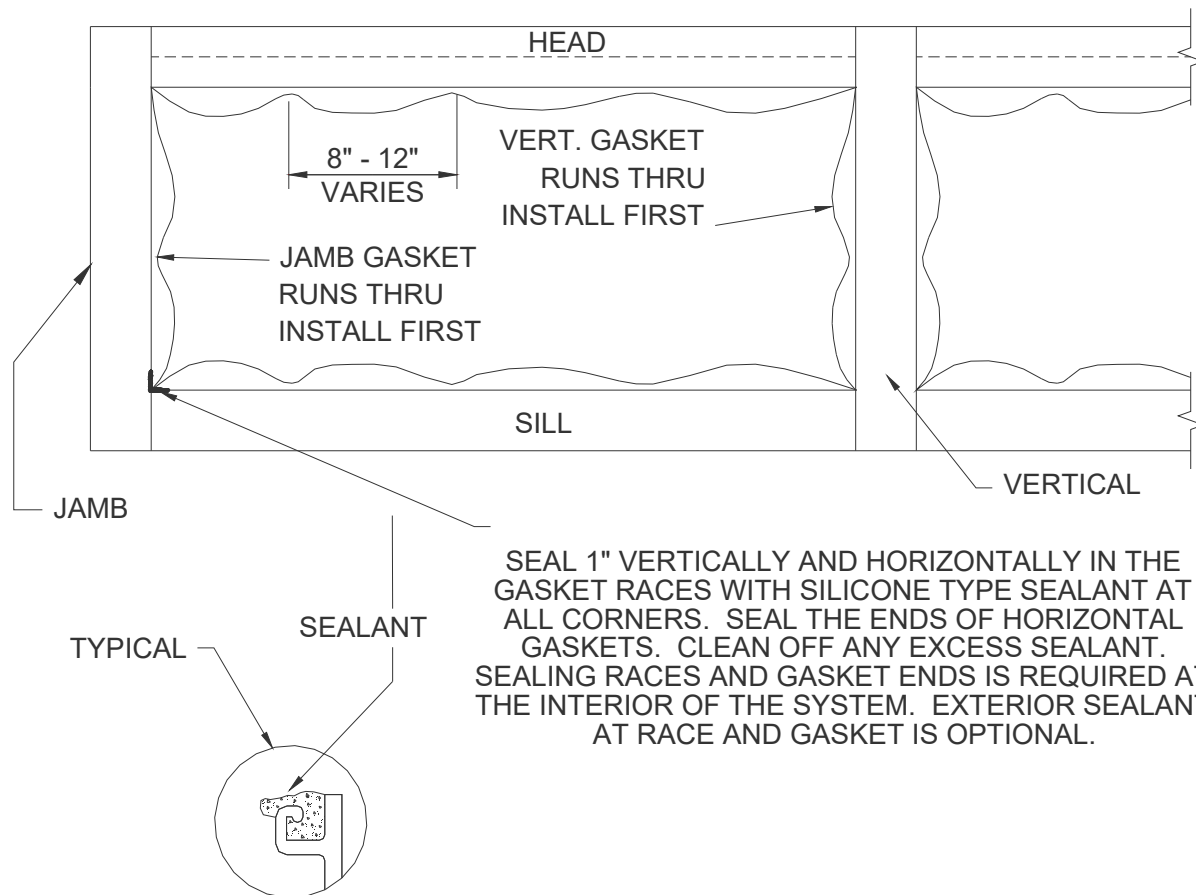

SEAL 1" VERTICALLY AND HORIZONTALLY IN THE GASKET RACES WITH SILICONE TYPE SEALANT AT ALL CORNERS. SEAL THE ENDS OF HORIZONTAL GASKETS. CLEAN OFF ANY EXCESS SEALANT. SEALING RACES AND GASKET ENDS IS REQUIRED AT THE INTERIOR OF THE SYSTEM. EXTERIOR SEALANT AT RACE AND GASKET IS OPTIONAL.

## SECTION IX: Glazing

(Includes Offset and Center-Set Glazing)

### Step 6) Glass Installation

A) Make sure the glazing blocks are still in place in the D.L.O. as instructed in Figures 98 and 99.

- For the following steps use Figures 102 and 103 below.

B) Position the glass on the appropriate side of the framing without the removable glass stop installed. Shift the glass into the deep pocket to begin glass installation.

C) Swing the opposite edge of the glass around to align with the glazing pocket.

D) Slide the glass into the shallow pocket and lower onto the setting blocks. Shift the glass until there is equal glass bite on both edges of the D.L.O. Ensure that the preinstalled gasket does not roll out of the gasket race when moving the glass unit into place.

E) Snap on the removable glass stop and install the antiwalk blocks and glazing gasket. Use the instructions on page 79 for gasket installation. See Figures 114 through 119 on pages 86, 87 and 88 for installation of the snap-in glass stop and antiwalk blocks.

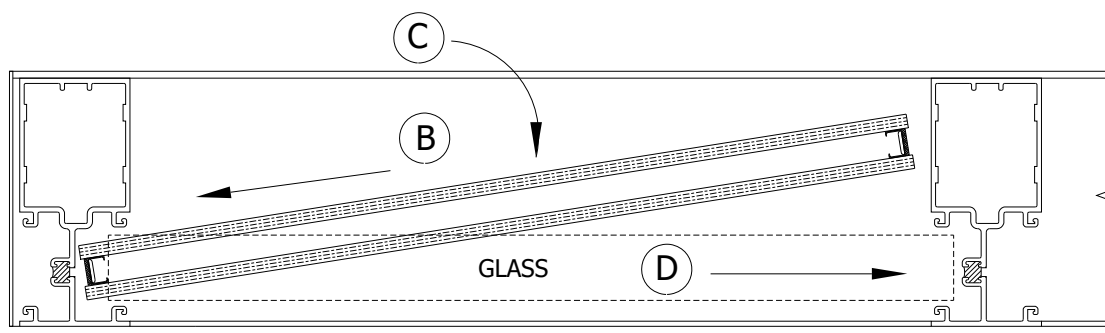

[FIG. 102]

**NOTE:**

This procedure works for all captured glazing configurations whether it is outside set (shown), inside set, or center-set glazing and inside (shown) or outside glazed.

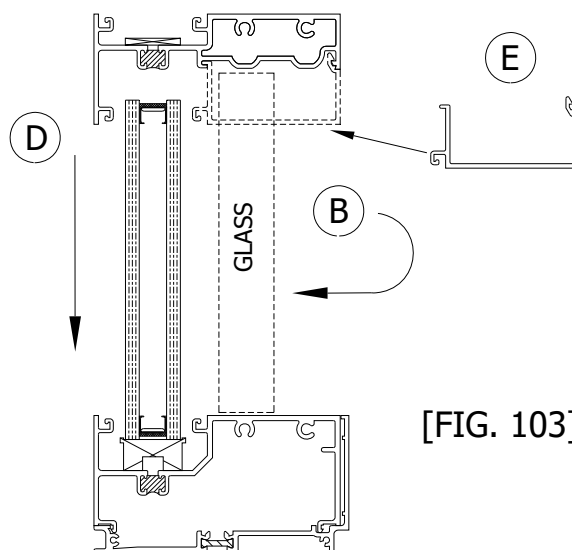

[FIG. 103]



## **SECTION IX: Glazing**

(Includes Captured and Structural Glazed Mullion Systems)

### **Step 7) Glass Installation**

#### **Structural Glazed Head and Sill Through**

A) Make sure the glazing blocks are still in place in the D.L.O. as instructed in Figures 98 and 99.

- For the following steps use Figures 104 through 106 below.

B) Prior to glass install, place WM80 tape into position on SSG mullion.

C) Position the glass on the appropriate side of the framing without the removable glass stop installed. Shift the glass out past the structural glaze mullion and into the deep pocket to begin glass installation, ensure the glass does not wipe the WM80 tape out of position.

D) Swing the opposite edge of the glass around to align with the glazing pocket.

E) Slide the glass until there is the correct glass bite shown on both D.L.O. edges. (7/16" @ captured vertical and 3/4" at SSG vertical.)

F) Snap on the removable glass stop and install the antiwalk blocks and glazing gasket. Use the instructions on page 79 for gasket installation. See Figures 114 through 119 on pages 86, 87 and 88 for installation of the snap-in glass stop and antiwalk blocks.

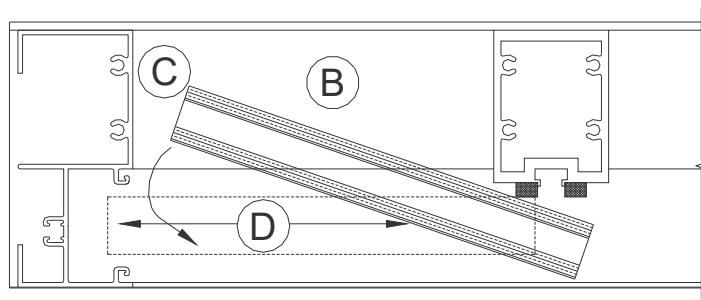

[FIG. 104]

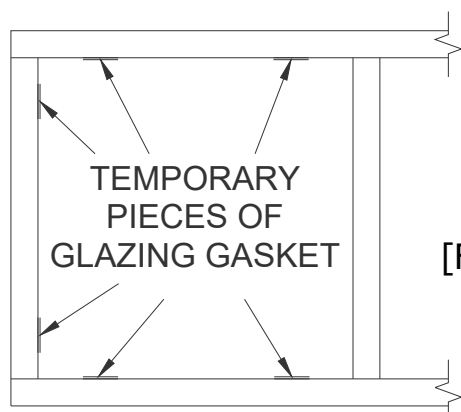

[FIG. 105]

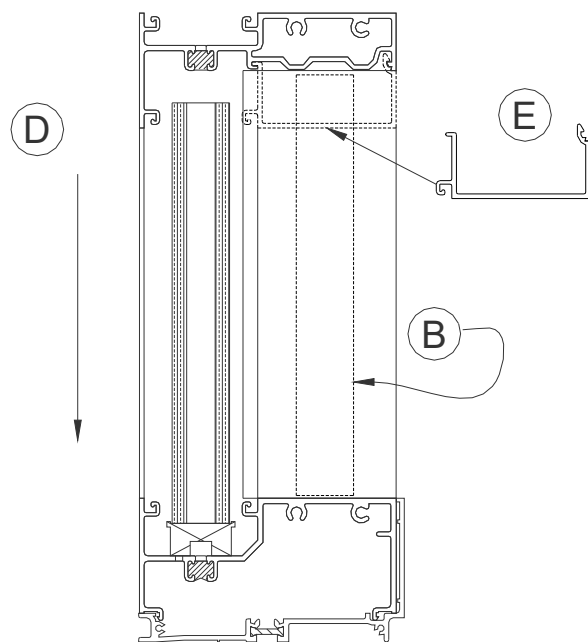

[FIG. 106]

## SECTION IX: Glazing

(Includes Captured and Structural Glazed Mullion Systems)

### Step 8) Glass Installation

#### Structural Glazed Vertical Through

- For the following steps use Figures 107 through 109.

A) Make sure the setting blocks are placed at 1/4 points in each D.L.O. or as required on the architectural drawings. See Figure 99 on page 78.

B) Prior to glass install, place WM80 tape into position on SSG mullion.

C) Position the glass at the exterior of the framing with the head and sill face covers removed. Lift the glass into the frame and onto the setting blocks; ensure the glass does not wipe the WM80 tape out of position.

D) Shift the glass into the pocket in the perimeter jamb until there is the correct glass bite on both edges of the D.L.O. (7/16" captured vertical or 3/4" SSG vertical).

E) Install the appropriate covers. Place temporary pieces of the glazing gasket along the head, perimeter jamb, and sill. Place the temporary glazing clips in the structural mullion race, and rotate to hold glass at the structural mullion. See Figure 108. Install all glazing gaskets. See Figure 101 on page 79. Install the next lite before filling the structural glazing gap. See Figure 110 on page 83.

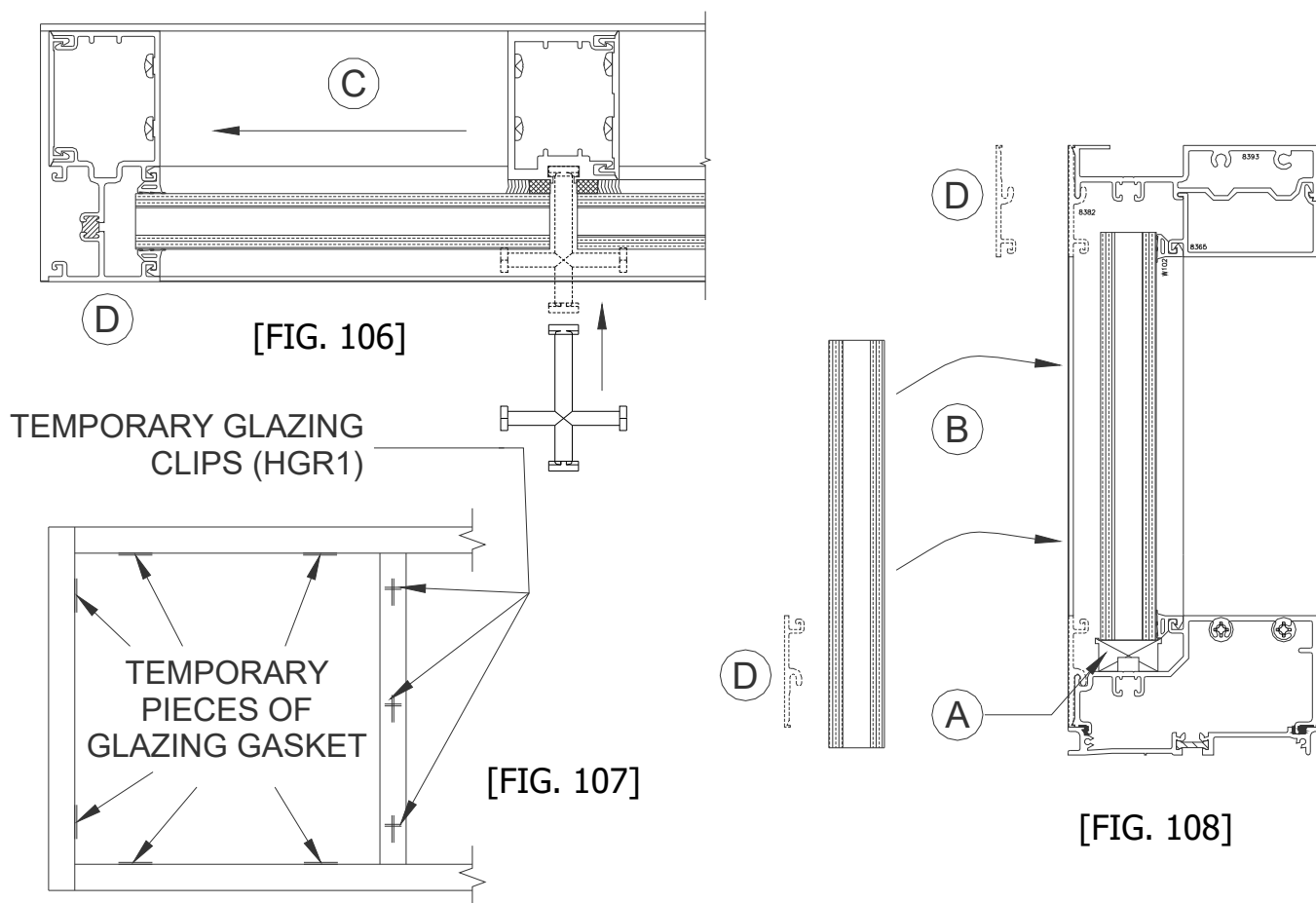

## **SECTION IX: Glazing**

### **(Includes Captured and Structural Glazed Mullion Systems)**

#### **Filling the Structural Glazing Gap**

-This procedure applies to the 2-piece structural glazed vertical, the head & sill thru structural glazed vertical, & the 90 degree structural glaze corner-

After the interior sealant has cured, typically an overnight setup is required, mask off the glass edges with masking tape to minimize cleanup and provide a professional appearance. Then remove the temporary glazing clips and proceed with filling the void between the glass units at the exterior with backer rod and structural silicone sealant for a weather tight seal. At the horizontal members, fill the cavity with sealant to fill the void out to the gasket. See Figure 110. Tool the sealant using a putty knife across the glass edges. Remove excess silicone from the glass surface by removing the masking tape before a skin begins to form. Any excess sealant on the glass units can be removed with a razor blade.

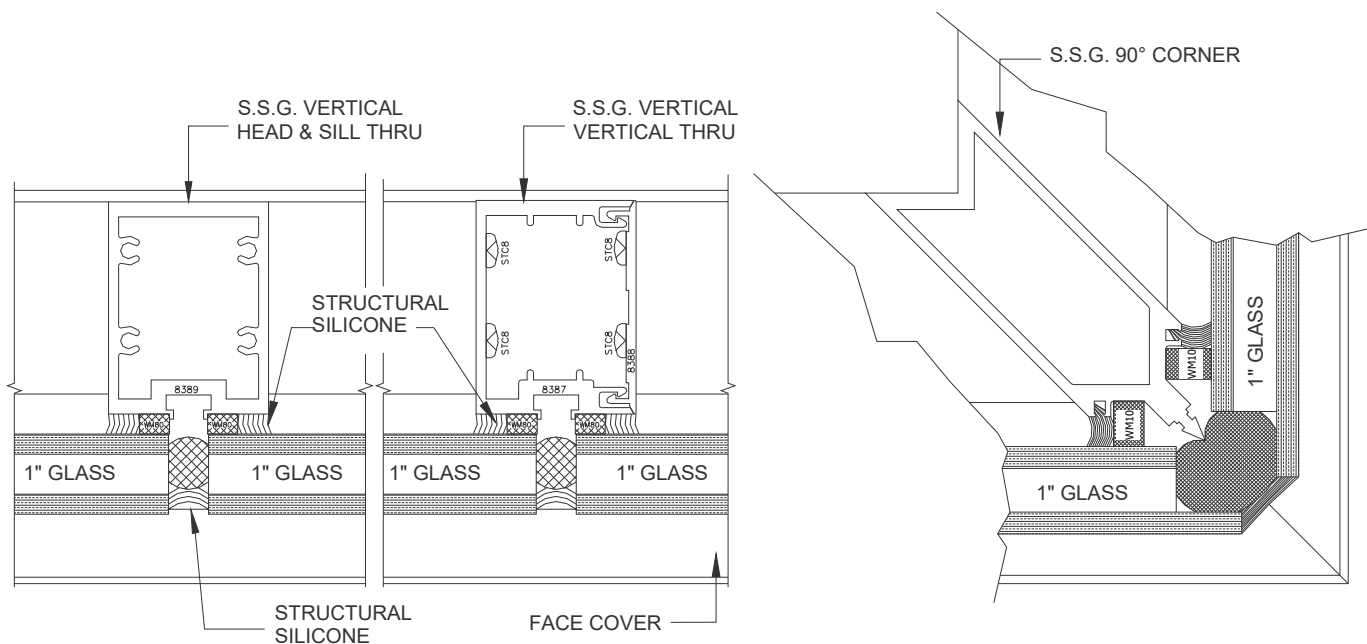

[FIG. 110]

**Note:**

The success of structural silicone glazed projects has been the result of compatibility tests performed on actual materials supplied to the project. The installer must make sure that successful compatibility tests are performed in accordance with the silicone manufacturer's recommendations and procedures.

## SECTION IX: Glazing

### Face Cover Splicing

Splicing of the head and sill face covers can be accomplished at any place along the horizontal span. Splicing of the intermediate horizontal face covers must be done at the centerline of a vertical mullion. Ensure that the face cover end cuts are square, clean of burrs or sharp edges, and clean of all cutting oils or other contaminants. Space the face covers 1/2" apart at the required splice area. If necessary, use small diameter backer rod to support the splice joint sealant. Fill the splice joint gap with a silicone type sealant, and tool smooth to create a weather tight and cosmetic seal. See Figure 111.

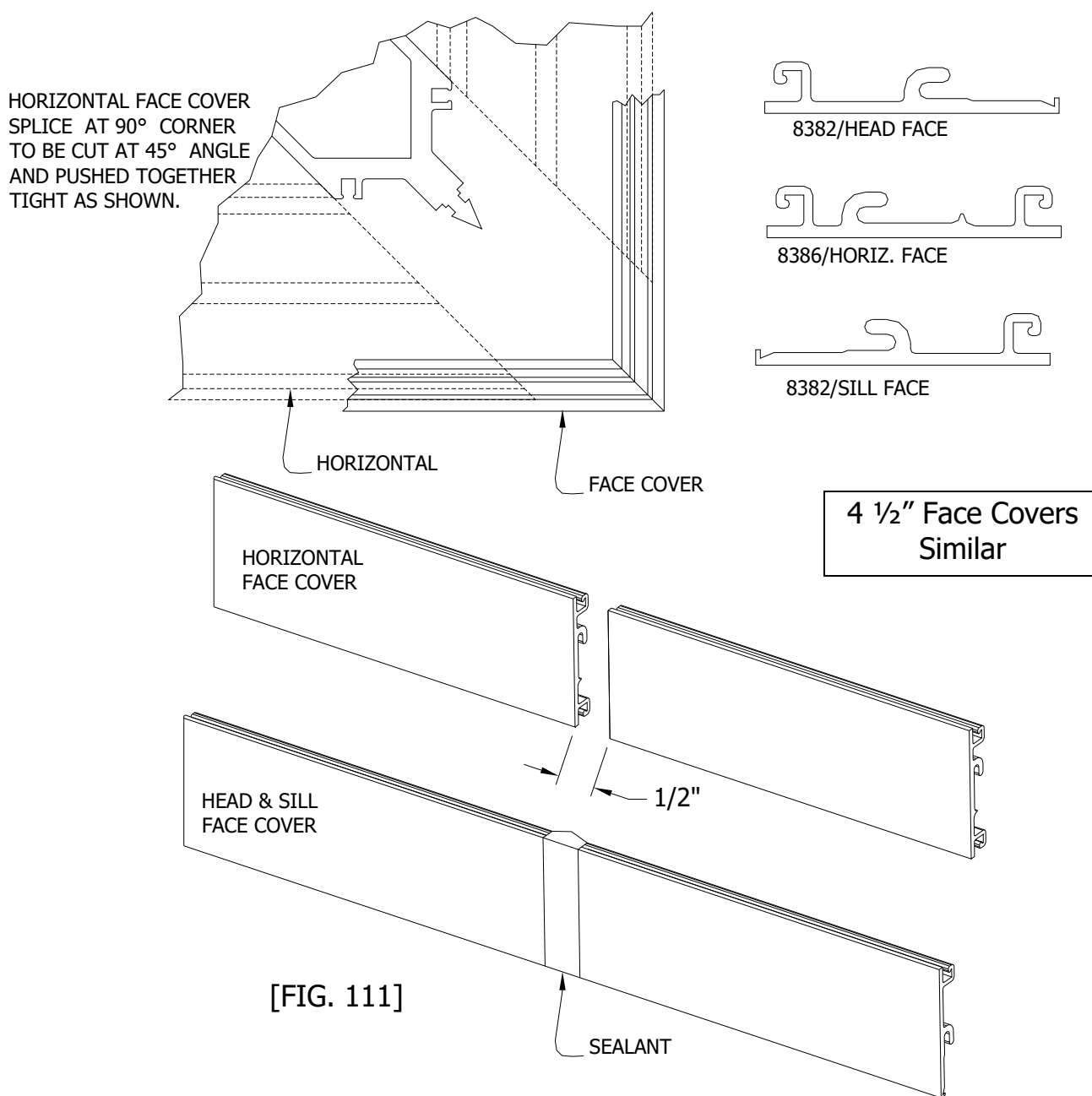

## SECTION IX: Glazing

### Head and Sill Splicing

Splicing of the head and sill is to be placed at mid D.L.O., at a maximum of 20'-0". Ensure that the end cuts are square, clean of burrs or sharp edges, and clean of all cutting oils or other contaminants. Space head and sill 1/2" apart at the required splice area. Fill the splice joint gap with a silicone type sealant, and tool smooth to create a weather tight and cosmetic seal. See Figure 112 for head and Figure 113 for sill.

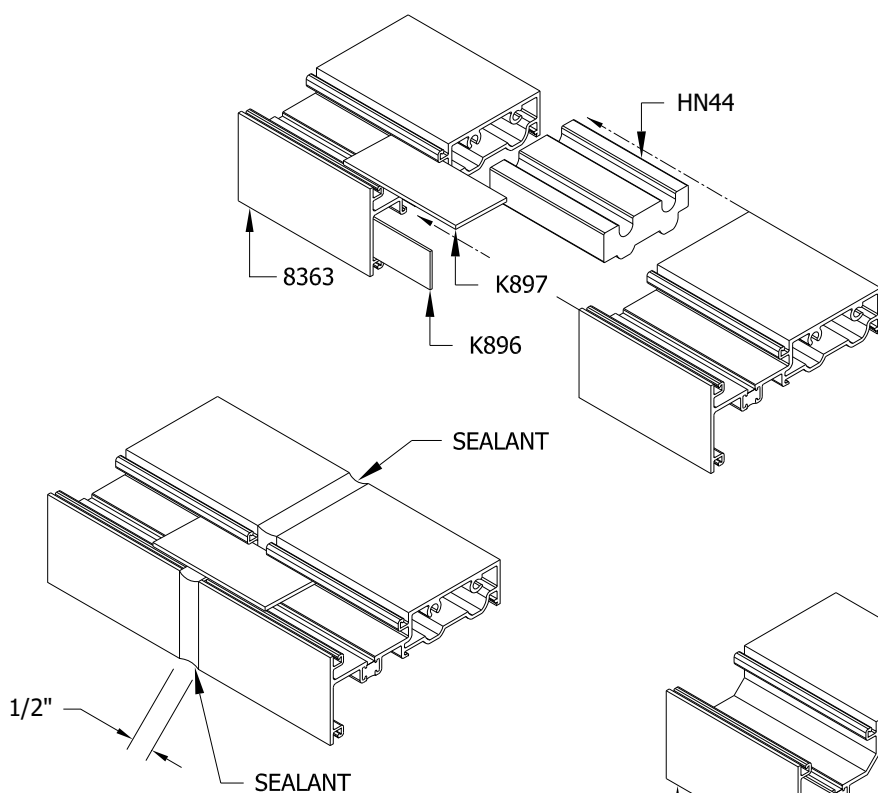

[FIG. 112]

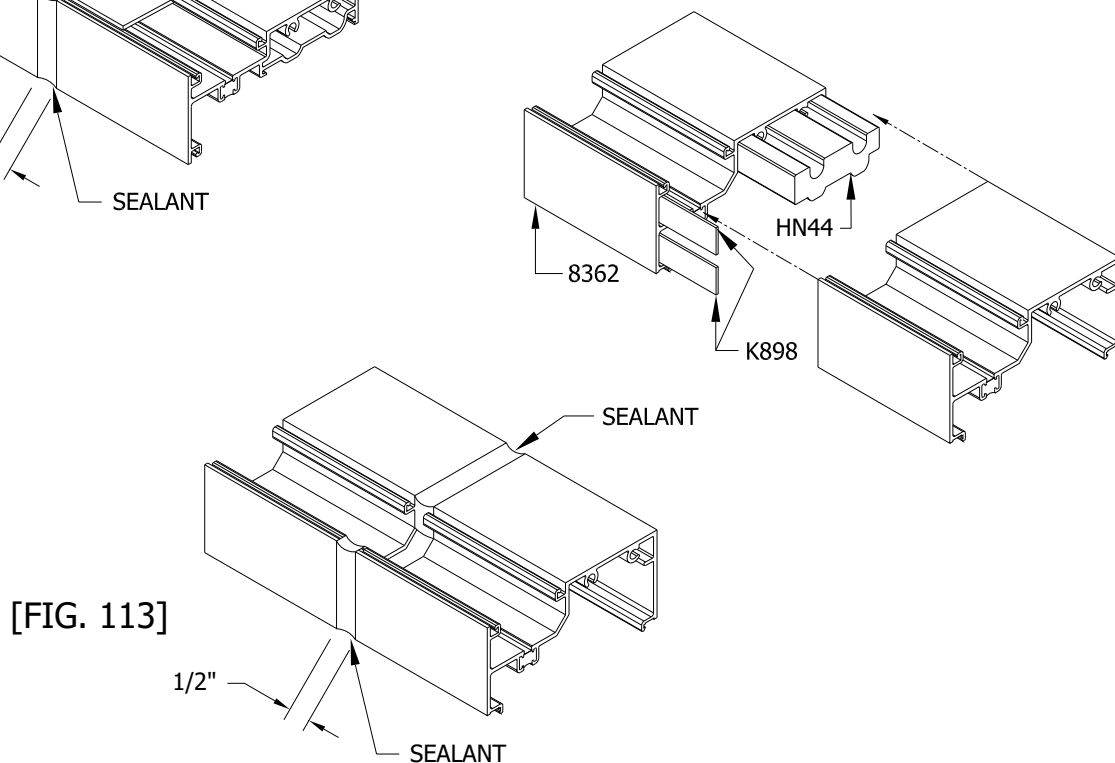

[FIG. 113]

## SECTION IX: Glazing

(Includes Offset and Center-Set Glazing)

### Step 11) Installing Removable Glass Stop

After the glazing unit is installed, the removable glass stop must be placed in position before the glazing gaskets can be installed. Ensure the glass stop hook track is clean and free of oil and dirt. Run a continuous bead of silicone sealant at the areas shown in Figures 114 through 116 below. Before the sealant begins to cure, place the glass stop into position and rotate the snap leg up to snap the stop into place. Strong hand pressure or a slight tap with a mallet will ensure the glass stop snap is engaged. This procedure applies to both inside and outside glazed configurations. (Inside glazed shown.)

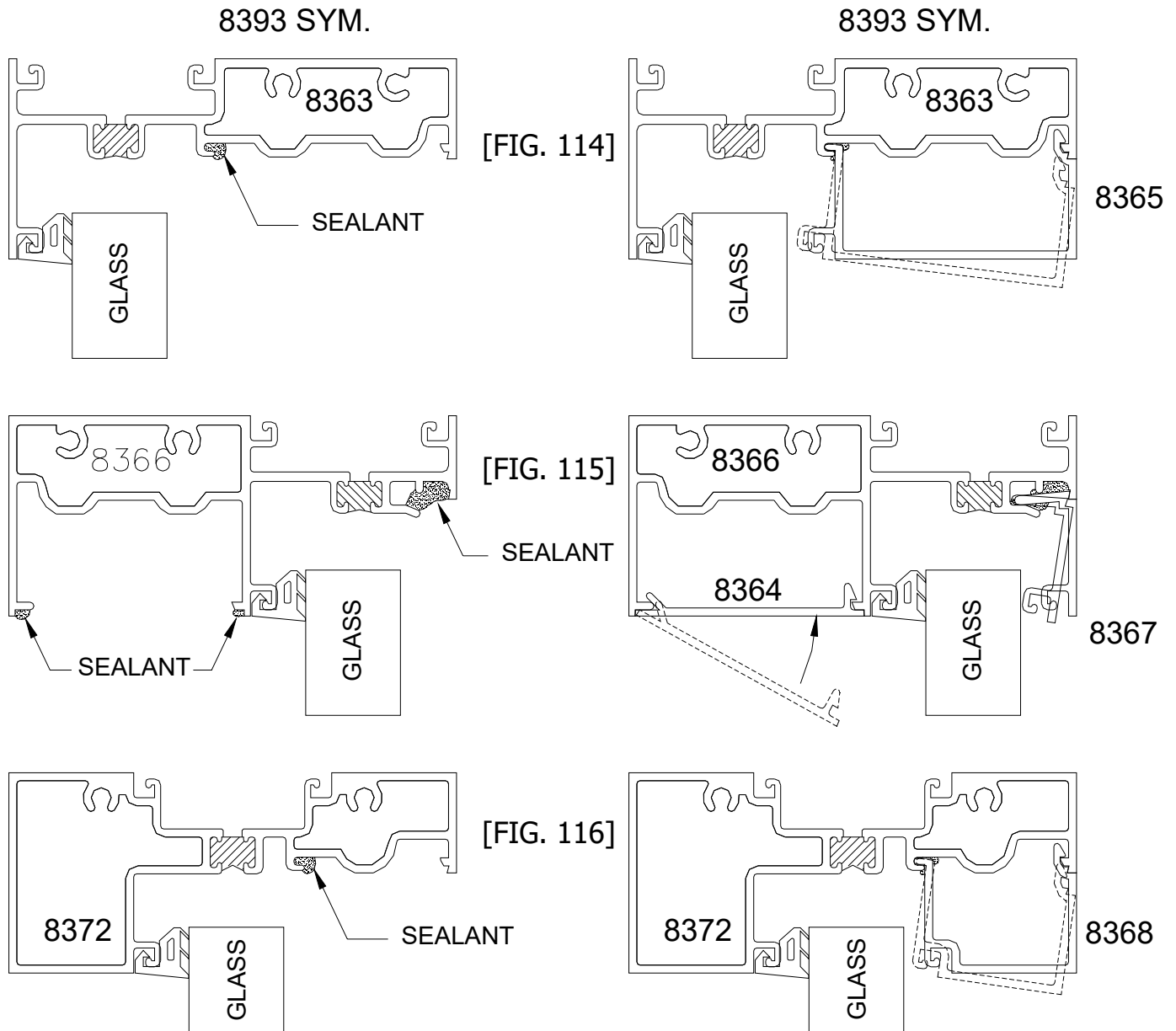

## **SECTION IX: Glazing**

(Includes Offset and Center-Set Glazing)

### **Step 12) Installing Antiwalk Block**

After the removable glass stop is installed, ensure the glass unit is pushed up tight against the preinstalled gasket and as far into the shallow glass pocket as possible. Stretch the antiwalk block out as shown in Figure 117 on this page. Slide the stretched out block between the glass unit and glazing gasket track and push it fully into the deep glass pocket at the midpoint of the glass unit.

USE HN50 FOR 8349, 8353, 8357, & 8361.  
USE HN52 FOR 8354, 8355, 8359 & 8439

USE AT DEEP POCKETS ONLY.

[FIG. 117]

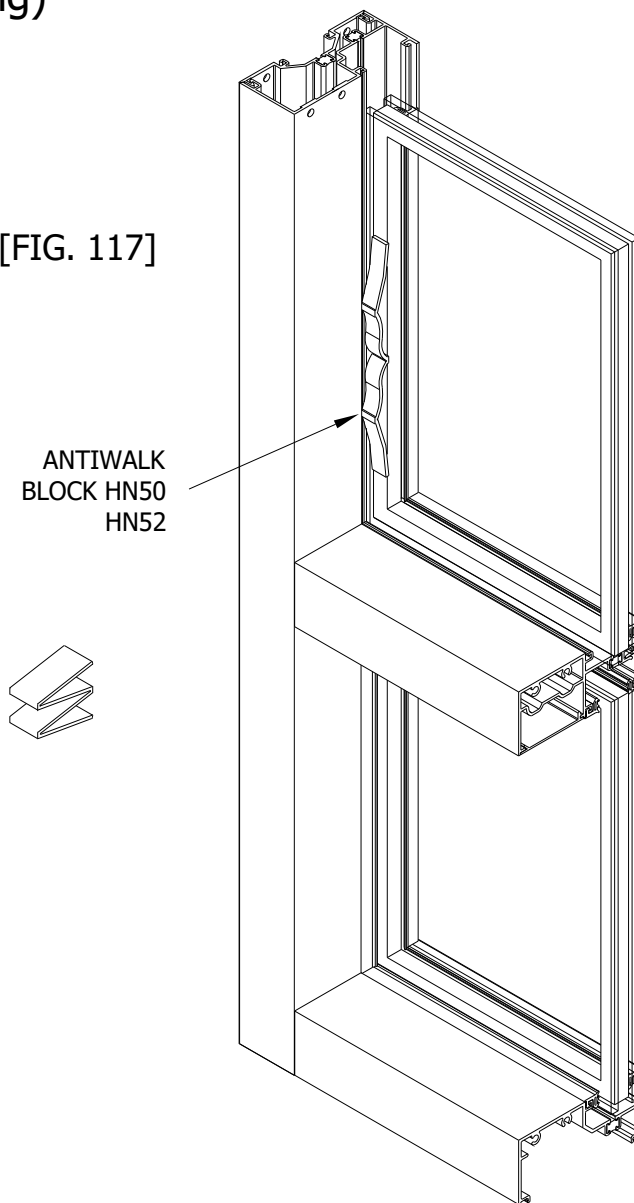

### **Step 13) Deglazing with Antiwalk Blocks**

Remove the glazing gaskets from both sides of the glass unit. Push the glass fully to the shallow pocket and either the interior or exterior side of the pocket. Use a hooked tool to pull the antiwalk block from the glass pocket. See Figure 118 on this page. Remove the glass by following the glass installation procedure on pages 76-79 in reverse.

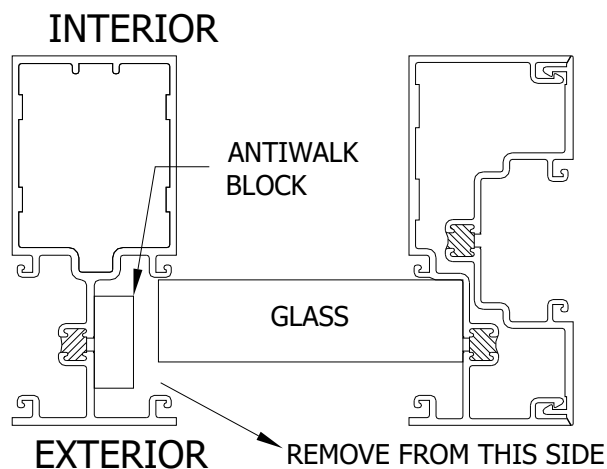

[FIG. 118]

## SECTION IX: Glazing

(Includes Offset and Center-Set Glazing)

### Step 14) Door Transom Glazing

Variations in transom glazing are available to match the sidelite glazing configurations or can be placed in line with the door plane for continuity of the system face. See Figures 119 and 120 below for specific transom glazing installation.

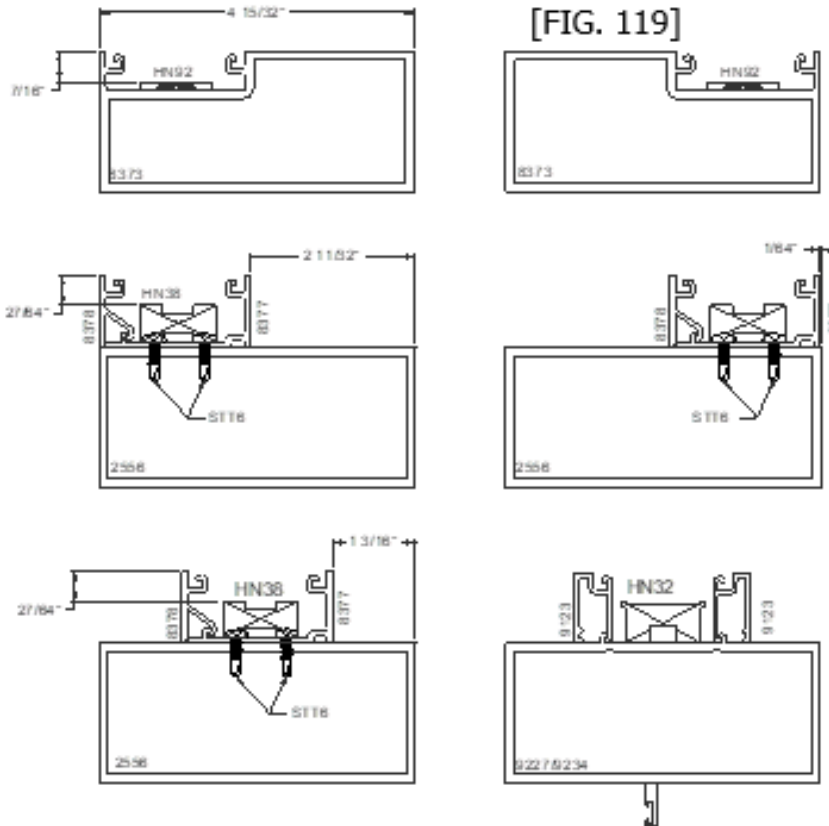

[FIG. 119]

[FIG. 120]

HORIZONTAL CUT LENGTH =  
TRANSOM OPENING WIDTH

VERTICAL CUT LENGTH =  
TRANSOM OPENING HEIGHT  
OR

VERTICAL CUT LENGTH =  
TRANSOM OPENING  
HEIGHT - APPLIED STOP  
HEIGHT

(When applied horizontal stops  
are used.)

THE EXTERIOR APPLIED  
GLAZING BEAD CUT LENGTH =  
D.L.O. - 1/8" TO ALLOW 1/16" GAP  
AT EACH END FOR WEEPAGE.

SCREW SPLINE  
JAMBS SIMILAR

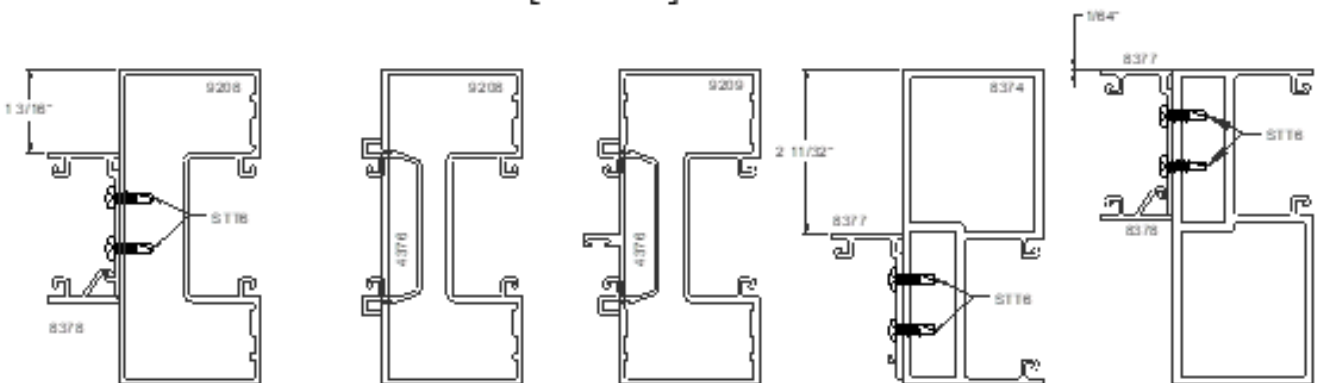



## SECTION IX: Glazing

(Includes Offset and Center-Set Glazing)

When applied transom glazing adaptors are used, the standard glass size formula must be used; however, the D.L.O. size must be figured from the innermost edge of the glass stops. See Figures 121 and 122 below.

[FIG. 121]

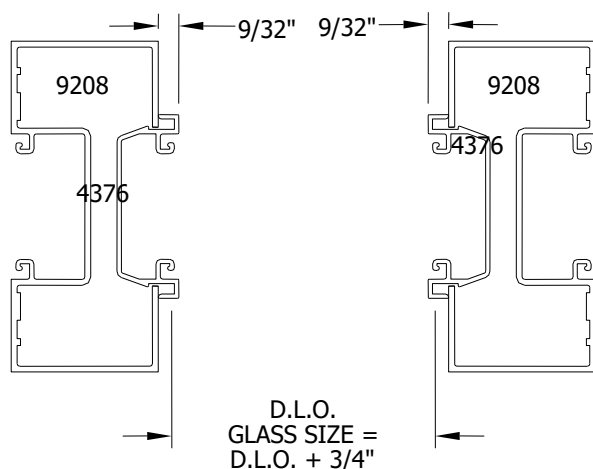

[FIG. 122]

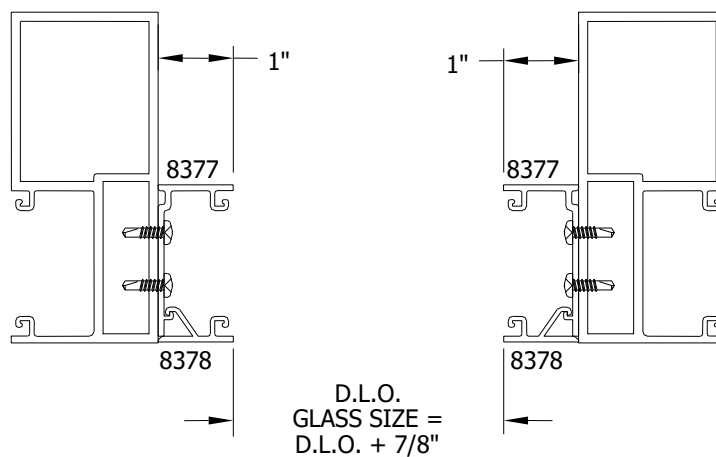

Use silicone type sealant in the sealant track on glass stop 8377. Use STT6 fasteners 3" from each end and stagger 12" on center to attach the 8377 stop. Horizontal glass stops should run through. After installation of 8377 or 9123 glass stops, seal the joint between the stop and the doorjamb with silicone type sealant and tool smooth for a watertight seal. 9123 stop must also have a cap seal at the hook area where the stop locks into the door header. 8377 stop should always be on the interior of the system. See Figures 123 through 125 on this page.

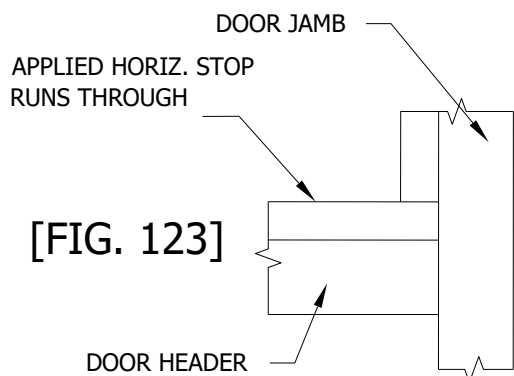

[FIG. 123]

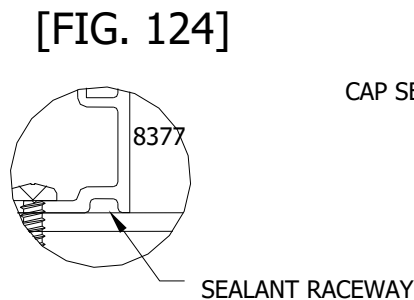

[FIG. 124]

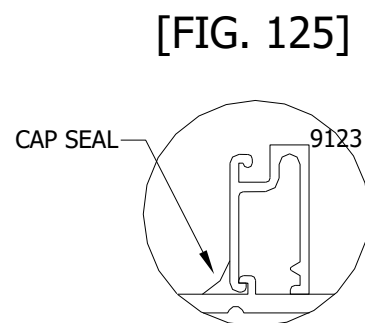

[FIG. 125]

## SECTION X: Door Stop Installation

(Includes Offset and Center-Set Glazing)

### Step 1) Door Stop Cut Length and Installation

Install the applied door stop into position on the door frame by spacing it off the exterior face of the door frame at the appropriate dimension, depending on door thickness. See Figures 126 and 127 below. Using STT6 fasteners 3" from each end and 12" O.C., fasten the door stop to the door header and door jamb. After determining that the door stops are in the correct position, apply the door stop cover by snapping it into the door stop raceway.

**HORIZONTAL CUT LENGTH = DOOR OPENING WIDTH**

**VERTICAL CUT LENGTH = [DOOR OPENING HEIGHT minus HORIZONTAL DOOR STOP HEIGHT minus THRESHOLD HEIGHT]**

[FIG. 126]

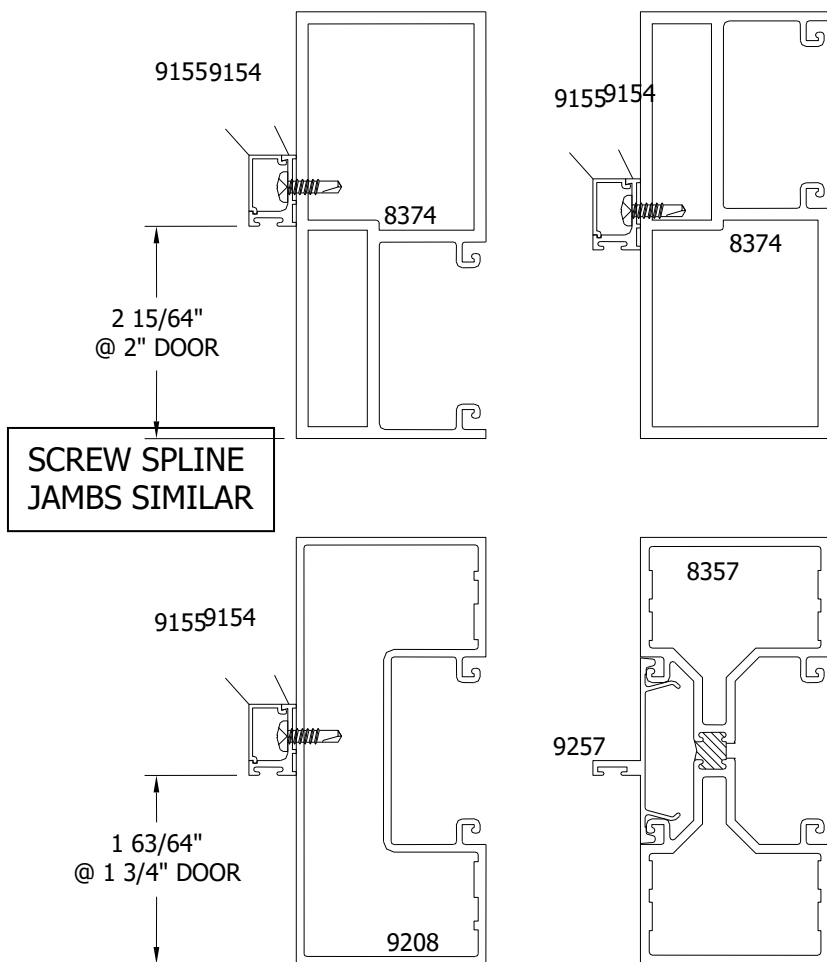

[FIG. 127]

